



PRELIMINARY DATA SHEET

Revision: 1.2

Release date: 25 Dec 2017

RDA5981A

IEEE802.11b/g/n MCU WIFI

1. General Description

RDA5981A is a low power MCU with IEEE802.11b/g/n MAC/PHY/radio integrated into one chip. TCP/IP protocols along with SSL are included, providing improved link robustness, extended range, and increased performance. For the highest integration level, the required board space has been minimized and customer cost has been reduced. Manufacturers can easily and fast integrate RDA5981A on their product to enable a rapid time to market.

RDA5981A uses a compact 5×5mm² QFN package, 0.4mm pitch QFN-40.

1.1 WLAN Features

- CMOS single-chip fully-integrated radio, PHY and MAC
- 2.4GHz IEEE 802.11b/g/n
- Internal PA, LNA
- Data rates up to 150Mbps with 20/40 MHz bandwidth
- Dynamic TX power saving
- Low power listen mode
- Fast AGC control
- Support WPS, WMM
- Support WPA, WPA2, WEP, TKIP, CCMP
- Support STA, softAP, P2P, STA+softAp, STA+P2P
- Support A-MPDU, A-MSDU, HT-BA
- Light Weight TCP/IP protocol

1.2 MCU Features

- Integrated ARM-CM4 MCU, Maximum clock Frequency 160MHz
- Integrated MPU and mbed uvisor supported to isolate security domains
- Up to 352KBytes internal sram for WIFI protocol and application developments
- SPI / UART / USB2.0 interface allows simple interfacing to host device
- UART with an AT command set
- Integrated hardware crypto accelerator AES/RSA
- Integrated true random number generator (TRNG) and CRC accelerator
- Support external psram interface
- Integrated 8Mbit SPI flash in package
- Integrated a bunch of configurable GPIOs with external level/edge trigger/wakeup
- Integrated UART×2/I2S×2/I2C×1 /PWM×8/SPI×4/SDMMC×1/USB2.0×1
- Integrated 2 channels application ADC
- Integrated watchdog and low power timer
- 16×16 bits eFuse configuration
- Support freeRTOS/mbedOS5.1

1.3 Applications

- IOT devices
- Smart home
- Wi-Fi speaker/home audio
- Smart watch

2. Block Description

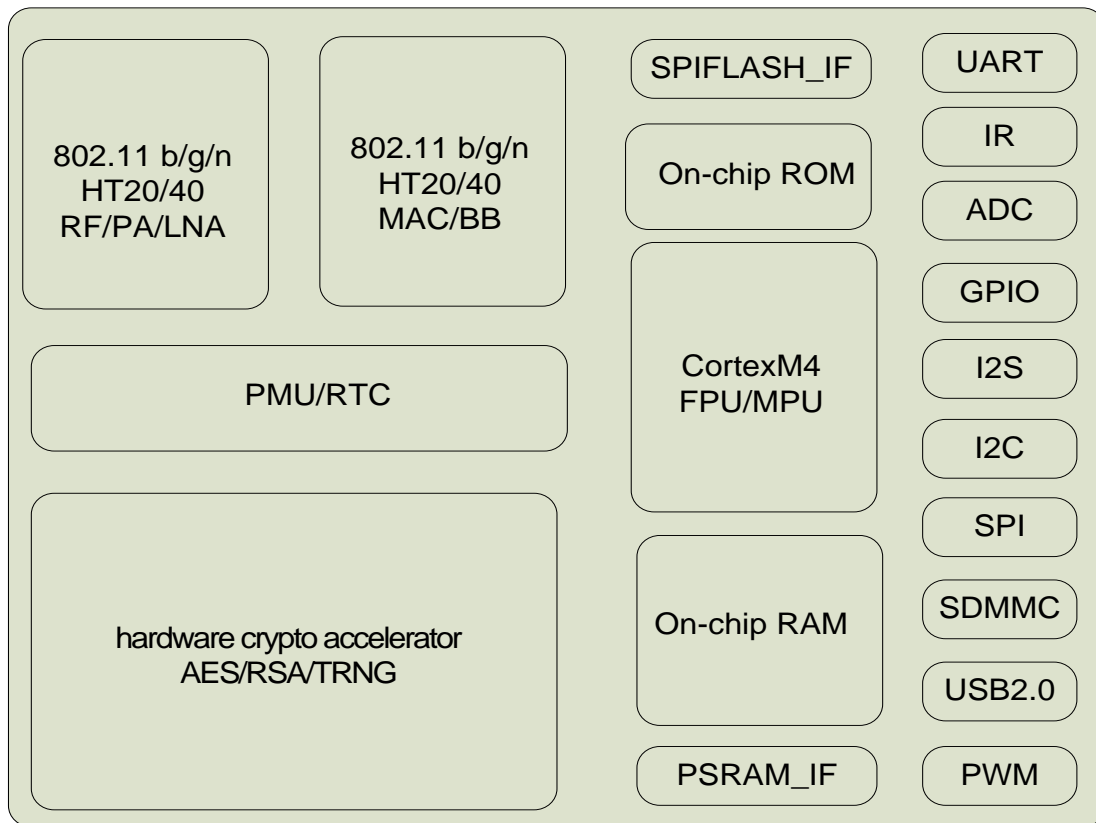

Figure2-1 RDA5981A Block Diagram

3. Functional Description

3.1 Memory System

RDA5981A integrates ROM, internal RAM and SPI nor flash to provide applications with a variety of memory requirements.

3.1.1 Memory Map

Table 3-1 RDA5981A Memory Map

Component	Address Range	Size	comments
MEMORY			
BOOT_ROM	0x0000_0000-0x0000_FFFF	64K	
I_SRAM	0x0010_0000-0x0011_FFFF	128K	
D_SRAM	0x0018_0000-0x0018_FFFF	64K	
PSRAM	0x1000_0000-0x13FF_EFFF data	64M	
FLASH	0x1400_0000-0x147F_FFFF FLASH data	8M	
I-cache	0x1800_0000-0x1FFF_FFFF I-cache		
LOGIC			
SCU	0x40000000-0x40000FFF	4K	
GPIO	0x40001000-0x40001FFF	4K	
TIMER	0x40002000-0x40002FFF	4K	
I2C_master	0x40003000-0x40003FFF	4K	
PWM	0x40004000-0x40004FFF	4K	
PSRAM_CFG	0x40005000-0x40005FFF	4K	
SDMMC	0x40006000-0x40006FFF	4K	
I2C	0x40010000-0x40010FFF	4K	
UART1	0x40012000-0x40012FFF	4K	
AHB_EXIF	0x40013000-0x40013FFF	4K	
WIFI_PA	0x40020000-0x40021FFF	8K	
WIFI_CE	0x40022000-0x40022FFF	4K	
WLAN_MON	0x40024000-0x40027FFF	20K	
SDIO	0x40030000-0x40030FFF	4K	
USB	0x40031000-0x40031FFF	4K	
MEMC0	0x40100000-0x4017FFFF	512k	
UART2	0x40180000-0x40180FFF	4K	
DMA_CFG	0x40181000-0x40181FFF	4K	

3.1.2 Internal ROM

RDA5981A integrates internal ROM to provide basic functions:

- eFuse functions
- USB/SPI interface initialization
- MCU/Wi-Fi mode initialization

3.1.3 Internal RAM

RDA5981A integrates:

- 96K Bytes SRAM for user
- 32K Bytes icache

3.1.4 SPI Nor FLASH

RDA5981A supports standard SPI mode and SPI-Quad mode and integrated 8Mbit flash in package.

3.2 GPIO Characteristics

Table 3-2 GPIO Configurable Function Summary Table

pad name	func0	func1	func2	func3	func4	func5	func6	func7	
GPIO9	gpio_9	tdi	tports9	sdmmc_clk	clkb_psram				pull down
GPIO7	gpio_7	trigger_bit	tports7	spi_miso_ex	clk_psram	sdmmc_d_1			pull down
GPIO8	gpio_8	tdo	tports8	i2s_in_bclk	pwm0				pull down
GPIO5	gpio_5	tck	tports5	i2s_in_ws	spi_cs_ex_1				pull down
GPIO4	gpio_4	tms	tports4	i2s_in_sd	spi_clk_ex			wl_active	pull down
UART_TX	uart_tx	gpio_27	intf_uart_rx	spi_cs_ex_3	pwm3				pull down
GPIO1	gpio_1	ntrst	tports1	i2s_out_sd	pw_pw1	uart2_rx		bt_prio	pull up
GPIO2	gpio_2	i2c_sda	tports2	i2s_out_ws	pw_lpg	uart2_tx		bt_state	pull up
GPIO3	gpio_3	i2c_sclk	tports3	i2s_out_bclk	pw_pwt	sdmmc_d_0		bt_freq	pull up
UART_RX	uart_rx	gpio_26		spi_cs_ex_2	pw_pw0				pull up
GPIO13	sda_sl1	gpio_13	tports13	sdmmc_d_3	cs_psram	pwm1	spi_miso_ex		pull down
GPIO12	scl_sl1	gpio_12	tports12	sdmmc_d_2	dqs_psram		spi_mosi_ex		pull down
GPIO25	gpio_25	spi_miso_ex	uart2_tx		pwm3				pull down
GPIO24	gpio_24	spi_mosi_ex	uart2_rx	spi_data_ex	pwm2				pull down
GPIO23	gpio_23	spi_cs_ex	rtsn_uart2	i2c_scl	pwm1				pull down
GPIO22	gpio_22	spi_clk_ex	rctsn_uart2	i2c_sda	pwm0				pull down
GPIO21	gpio_21	dq_7_psram							pull down
GPIO0	gpio_0	wifi_wakeup	tports0	sdmmc_cmd	pwm2				pull down
GPIO20	gpio_20	dq_6_psram							pull down

3.3 UART Interface Characteristics

RDA5981A supports 2 UARTs with configurable baud rate from 1200bps to 4Mbps.

3.4 I2S Interface Characteristics

RDA5981A supports 2 I2S interface; the I2S master BCLK supports 96/192/384/512/ 44.1/88.2KHz. The interface supports 16/32 bit per channel, the data format can be configured as 16/20/24bit per channel or decided by software (up to 24bit per channel).

3.5 I2C Interface Characteristics

RDA5981A supports 1 I2C standard interface. It supports master or slave I2C operation and 3 standard speed modes:

1. Standard mode (<100Kb/s)
2. Fast mode (<400Kb/s)
3. High-speed mode (<3.4Mb/s)

3.6 PWM Interface Characteristics

RDA5981A supports 8 PWM interfaces. Period and Duty of PWM is programmable. The Duty of PWM/PWT/PWL can be flexible configured between 0~100. The accurate of duty is 1%.The period are programmable, the software can select different clock to product long Period.

Table 3-3 PWM Period & Duty

Name	Number	Duty	Period	
PWM	4	1~100%	5us-256s	Standard PWM
PWT	1	1~100%	5us-4s	Standard PWM
LPG	1	<25%	<2s	The wave has a short pull up in a long period
PWL	2	1~100%	-	The wave is non-periodic, use for screen background light

3.7 SPI Interface Characteristics

RDA5981A supports 4 SPI interfaces, master only. The SPI clock rate is programmable and up to 20MHz. The data length can be configured by the software, the max data length is 64bit.

3.8 SDMMC Interface Characteristics

RDA5981A supports 1 SDMMC interface.

3.9 USB Interface Characteristics

RDA5981A supports USB interface.

4. General Specification

4.1 WLAN Section Electrical Characteristics

Table 4-1 DC Electrical Specification (Recommended Operation Conditions)

SYMBOL	DESCRIPTION	MIN	TYP	MAX	UNIT
V _{BAT}	Supply Voltage from battery or LDO	3.3	4.0	4.2	V
T _{amb}	Ambient Temperature	-20	27	+70	°C
V _{IL}	CMOS Low Level Input Voltage	0		0.3*V _{IO}	V
V _{IH}	CMOS High Level Input Voltage	0.7*V _{IO}		V _{IO}	V
V _{TH}	CMOS Threshold Voltage		0.5*V _{IO}		V

Table 4-2 DC Electrical Specification (Absolute Maximum Ratings)

SYMBOL	DESCRIPTION	MIN	TYP	MAX	UNIT
I _{IN}	Input Current	-10		+10	mA
V _{IN}	Input Voltage	-0.3		V _{IO} +0.3	V
V _{lna}	LNA Input Level			+10	dBm

4.2 Receiver Performance Specifications

PARAMETER	CONDITIONS	MIN	TYP	MAX	UNIT
Frequency range		2412	-	2484	GHz
Rx Sensitivity 802.11b @ 8% PER	1 Mbps DSSS		-92		dBm
	2 Mbps DSSS		-90		dBm
	5.5 Mbps DSSS		-88		dBm
	11 Mbps DSSS		-86		dBm
Rx Sensitivity 802.11g @ 10% PER	6 Mbps OFDM		-90		dBm
	9 Mbps OFDM		-88		dBm
	12 Mbps OFDM		-86		dBm
	18 Mbps OFDM		-85		dBm
	24 Mbps OFDM		-82		dBm
	36 Mbps OFDM		-78		dBm
	48 Mbps OFDM		-76		dBm
Rx Sensitivity (802.11n, 20M) @ 10% PER	MCS0		-88		dBm
	MCS1		-85		dBm
	MCS2		-83		dBm
	MCS3		-80		dBm

	MCS4		-77		dBm
	MCS5		-73		dBm
	MCS6		-71		dBm
	MCS7		-69		dBm
Rx Sensitivity (802.11n, 40M) @ 10% PER	MCS0		-87		dBm
	MCS1		-84		dBm
	MCS2		-82		dBm
	MCS3		-79		dBm
	MCS4		-76		dBm
	MCS5		-72		dBm
	MCS6		-70		dBm
Maximum Receive Level	11 Mbps (802.11b)		-3		dBm
	54 Mbps (802.11g)		-8		dBm
	MCS7 (802.11n)		-8		dBm

4.3 Transmitter Performance Specification

PARAMETER	CONDITIONS	MIN	TYP	MAX	UNIT
Frequency Range		2412	-	2484	MHz
Output Power	802.11b		18		dBm
	802.11g		15		dBm
	802.11n		14		dBm
	802.11n (HT40)		14		dBm
@ EVM	802.11b		-20		dB
	802.11g		-28		dB
	802.11n		-28		dB
	802.11n (HT40)		-28		dB

4.4 Power Consumption

PARAMETER	MIN	TYP	MAX	UNIT
WIFI OFF		22		uA
Deep Sleep		700		uA
RX mode		80		mA
TX mode (MCS7, duty ratio=100%)		220		mA

5. PINS Description

Table 5-1 Pin Types

Pin Type	Description
I/O	Digital input/output
I	Digital input
O	Digital output
A,I	Analog input
A,O	Analog output
A,I/O	Analog input/output
PWR	Power
GND	Ground

Table 5-2 RDA5981A Pins Description

PIN	NO.	TYPE	DESCRIPTION
VBAT	1	PWR	buck power supply
SW_GND	2	GND	buck ground
SW_Buck	3	PWR	Switching node of buck
VA18	4	PWR	1.8V power output
LX_Buck	5	PWR	Switching output
VD11	6	PWR	1.1V power output
GPIO9	7	I/O	General purpose input/output
V_CORE	8	PWR	digital core power in
USB_DN	9	I/O	USB negative signal
USB_DP	10	I/O	USB positive signal
GPADC0	11	I/O	General purpose ADC
GPIO7	12	I/O	General purpose input/output
GPIO8	13	I/O	General purpose input/output
GPIO5	14	I/O	General purpose input/output
GPIO4	15	I/O	General purpose input/output
UART_TX	16	I/O	UART_TX
PDN	17	I	Power Down signal of the chip
AVDD33_PAD	18	PWR	3.3V PA driver power in
AVDD33_PA	19	PWR	3.3V PA power in
RFIO	20	A,I/O	WIFI transmitter output/receiver input
GPIO1	21	I/O	General purpose input/output
GPIO2	22	I/O	General purpose input/output
GPIO3	23	I/O	General purpose input/output
UART_RX	24	I/O	UART_RX
AVDD_RF	25	PWR	1.8V RF power in
AVDD_CLK	26	PWR	1.8V clock power in
XIN	27	A,I	26M crystal input
XTAL	28	A,O	26M crystal output
GPIO13	29	I/O	General purpose input/output
GPIO12	30	I/O	General purpose input/output
GPIO25	31	I/O	General purpose input/output
GPIO24	32	I/O	General purpose input/output

GPIO23	33	I/O	General purpose input/output
GPIO22	34	I/O	General purpose input/output
GPIO21	35	I/O	General purpose input/output
GPIO0	36	I/O	General purpose input/output
VIO_LDO	37	I/O	I/O power output
VIO	38	PWR	I/O power supply
LDO33	39	PWR	3.3V LDO output
VBAT	40	PWR	power supply

6. Application Circuit

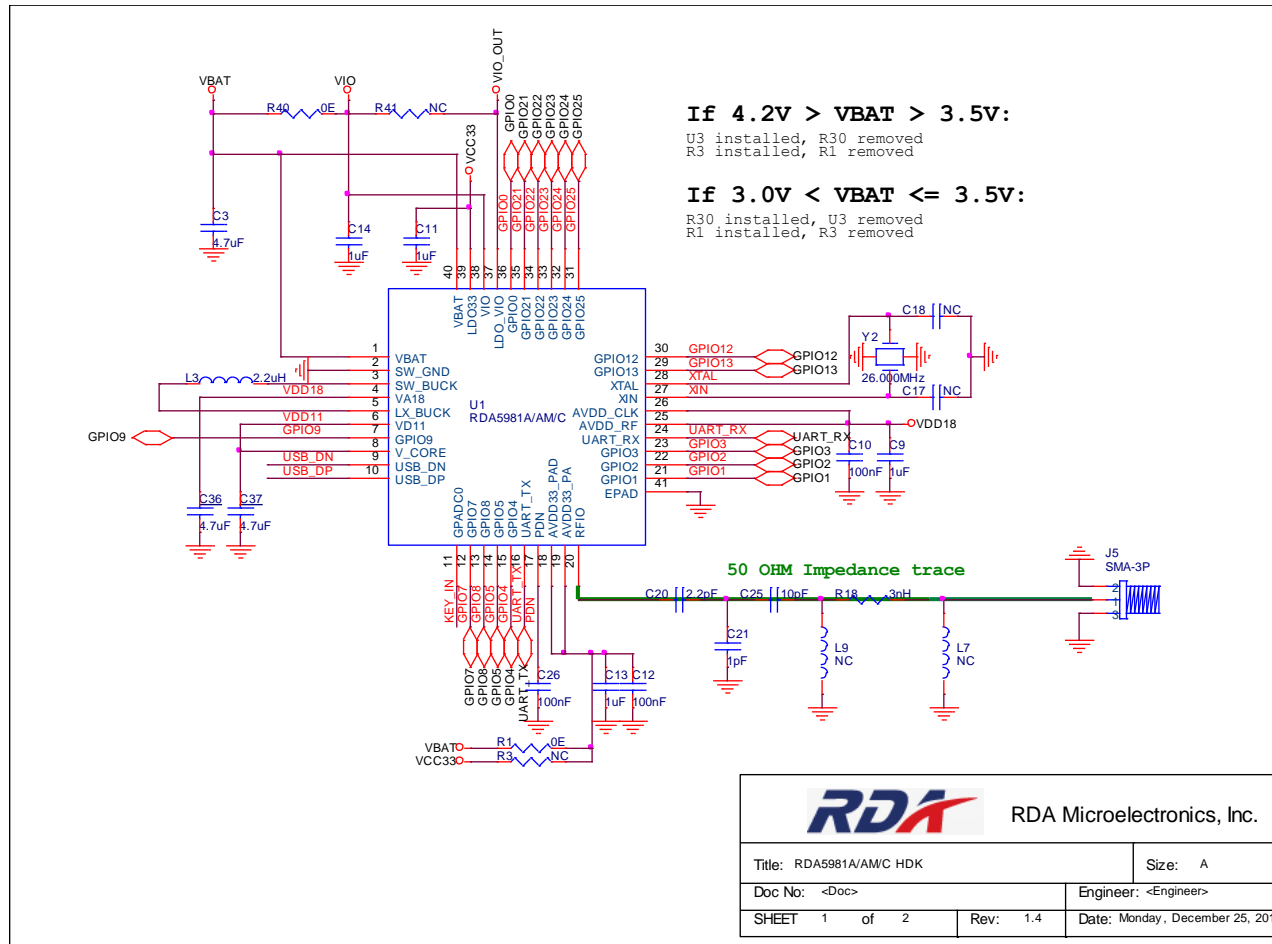

7. Package Physical Dimension

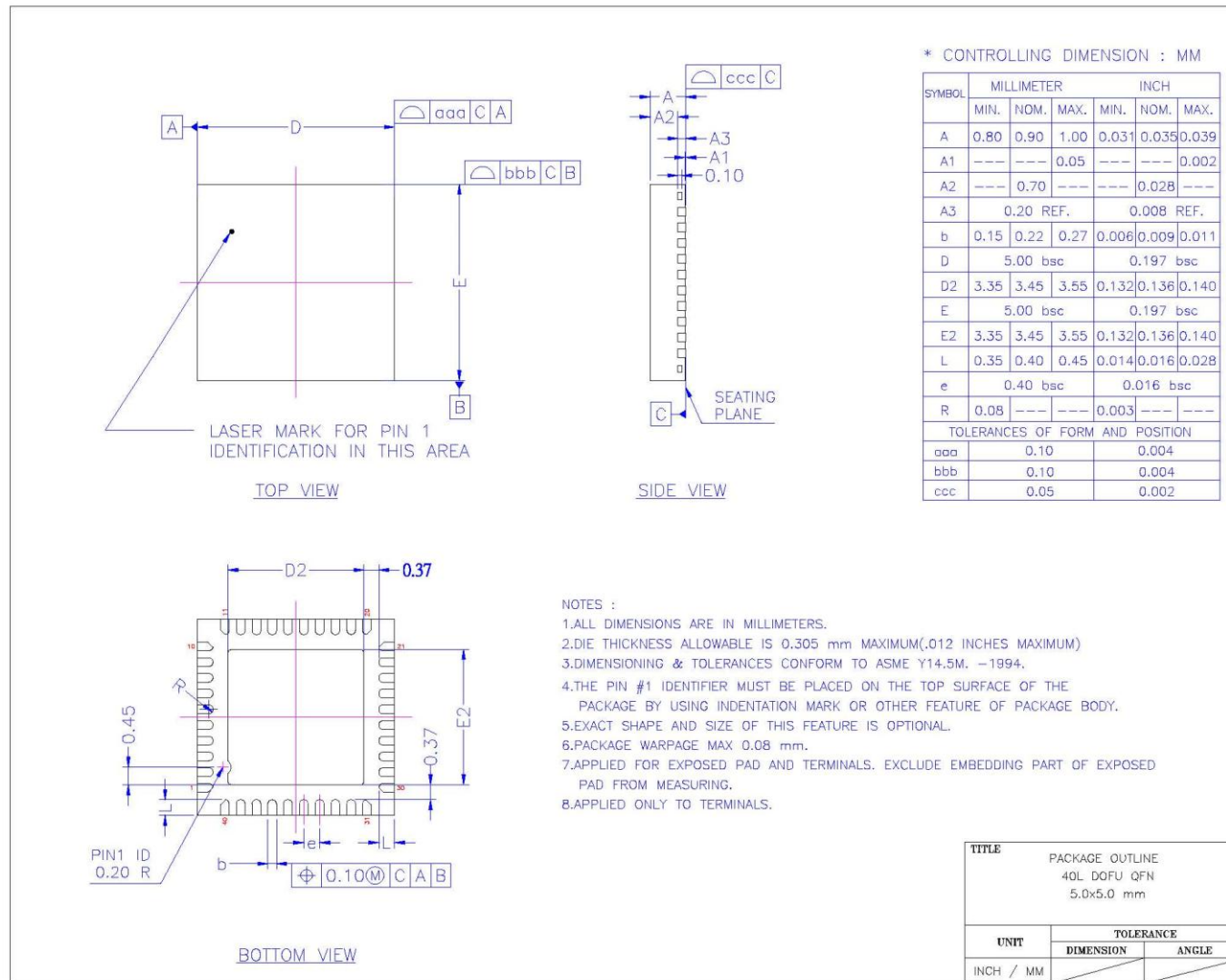

8. Recommended Reflow Profile

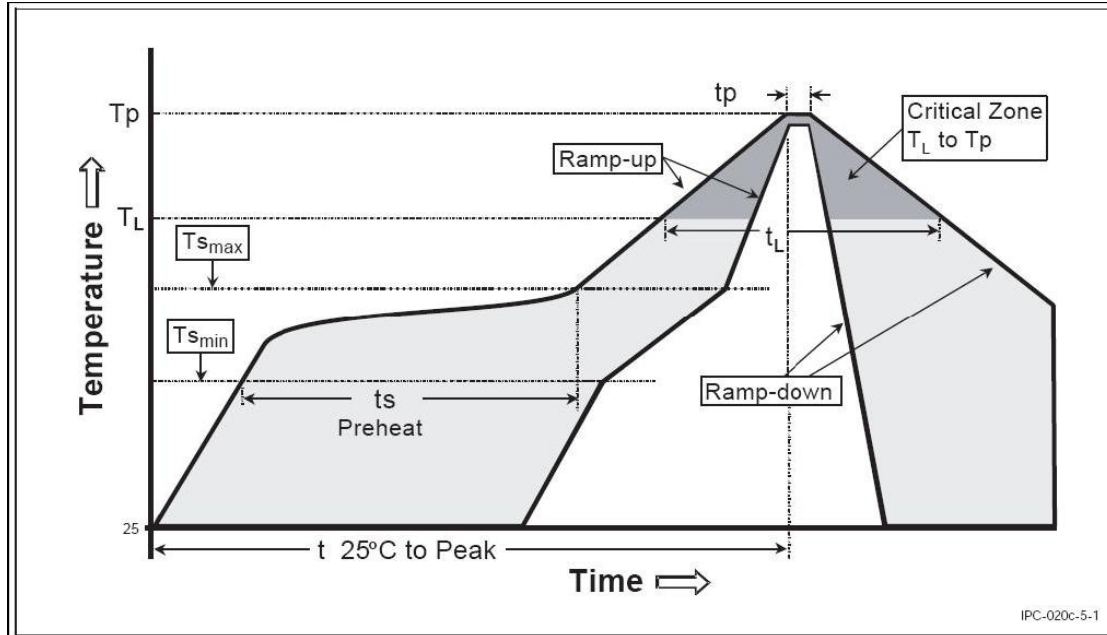

Figure.8-1 Classification Reflow Profile

Table 8-1 Classification Reflow Profiles

Profile Feature	Sn-Pb Eutectic Assembly	Pb-Free Assembly
Average Ramp-Up Rate (T_{smax} to T_p)	3 °C/second max.	3 °C/second max.
Preheat		
-Temperature Min (T_{smin})	100 °C	150 °C
-Temperature Max (T_{smax})	100 °C	200 °C
-Time (t_{smin} to t_{smax})	60-120 seconds	60-180 seconds
Time maintained above:		
-Temperature (T_L)	183 °C	217 °C
-Time (t_L)	60-150seconds	60-150 seconds
Peak /Classification Temperature(T_p)	See Table 8-2	See Table 8-3
Time within 5 oC of actual Peak Temperature (t_p)	10-30 seconds	20-40 seconds
Ramp-Down Rate	6 °C/second max.	6 °C/seconds max.
Time 25 oC to Peak Temperature	6 minutes max.	8 minutes max.

Table 8-2 Sn-Pb Eutectic Process – Package Peak Reflow Temperatures

Package Thickness	Volume mm3	Volume mm3
	<350	≥350
<2.5mm	240 + 0/-5 °C	225 + 0/-5 °C
≥2.5mm	225 + 0/-5 °C	225 + 0/-5 °C

Table 8-3 Pb-free Process – Package Classification Reflow Temperatures

Package Thickness	Volume mm3 <350	Volume mm3 350-2000	Volume mm3 >2000
<1.6mm	260 + 0 °C *	260 + 0 °C *	260 + 0 °C *
1.6mm – 2.5mm	260 + 0 °C *	250 + 0 °C *	245 + 0 °C *
≥2.5mm	250 + 0 °C *	245 + 0 °C *	245 + 0 °C *

*Tolerance : The device manufacturer/supplier shall assure process compatibility up to and including the stated classification temperature(this mean Peak reflow temperature + 0 °C. For example 260+ 0 °C) at the rated MSL Level.

Note 1: All temperature reference topside of the package. The temperature is measured on the package body surface.

Note 2: The profiling tolerance is + 0 °C, - X °C (based on machine variation capability)whatever is required to control the profile process but at no time will it exceed – 5 °C. The producer assures process compatibility at the peak reflow profile temperatures defined in Table 8-3.

Note 3: Package volume excludes external terminals (balls, bumps, lands, leads) and/or non-integral heat sinks.

Note 4: The maximum component temperature reached during reflow depends on package the thickness and volume. The use of convection reflow processes reduces the thermal gradients between packages. However, thermal gradients due to differences in thermal mass of SMD package may exist.

Note 5: Components intended for use in a “lead-free” assembly process shall be evaluated using the “lead free” classification temperatures and profiles defined in Table8-1, 8-2, 8-3 whether or not lead free.

9. Change List

The following table summarizes revisions to this document.

REV	DATE	CHANGE DESCRIPTION
V1.1		Primary Version
V1.2		Add general specification

10. RoHS Compliant

The product does not contain lead, mercury, cadmium, hexavalent chromium, polybrominated biphenyls (PBB) or polybrominated diphenyl ethers (PBDE), therefore is considered RoHS compliant.

11. ESD Precautions

ESD protection circuitry is contained in this device, but special handling precautions are required.

12. Disclaimer

The information provided here is believed to be reliable; RDA Microelectronics assumes no reliability for inaccuracies and omissions. RDA Microelectronics assumes no reliability for the use of this information and all such information should entirely be at the user's own risk. Specifications described and contained here are subjected to change without notice on the purpose of improving the design and performance. All of this information described herein should not be implied or granted for any third party. RDA Microelectronics does not authorize or warrant any RDA products for use in the life support devices or systems.

Copyright©2016 RDA Microelectronics Inc. All rights reserved



For technical questions and additional information about RDA Microelectronics Inc.:

Website: www.rdamicro.com

Mailbox: info@rdamicro.com

RDA Microelectronics (Beijing), Inc.

Tel: +86-10-58286588

Fax: +86-10-58286599