

## JDY-40 wireless serial port module

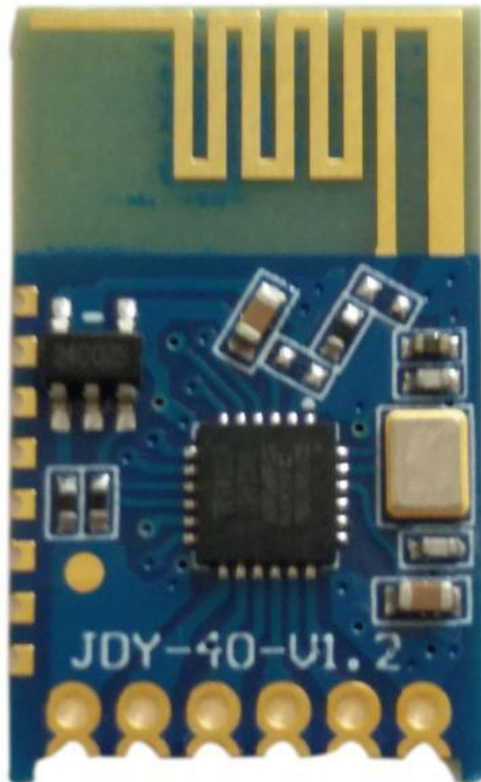

## JDY-40 pin definition

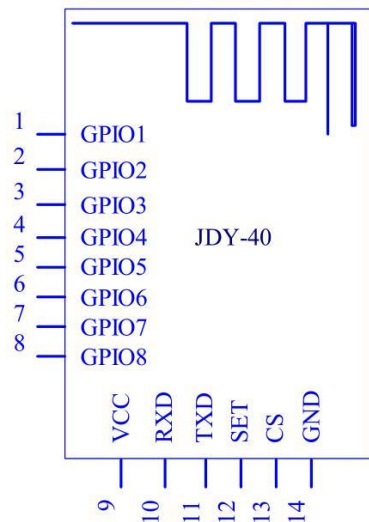

## Pin function description

Pin	Pin Names	Function
1	GPIO1	Input/output IO, which can be configured by AT+CLSS
2	GPIO2	Input/output IO, which can be configured by AT+CLSS
3	GPIO3	Input/output IO, which can be configured by AT+CLSS
4	GPIO4	Input/output IO, which can be configured by AT+CLSS
5	GPIO5	Input/output IO, which can be configured by AT+CLSS
6	GPIO6	Input/output IO, which can be configured by AT+CLSS
7	GPIO7	Input/output IO, which can be configured by AT+CLSS
8	GPIO8	Input/output IO, which can be configured by AT+CLSS
9	VCC	Power Supply (2.2V-3.6V)
10	RXD	Serial port input pin
11	TXD	Serial port output pin
12	SET	AT command switching pin (low level AT instruction, high level transparent transmission)
13	CS	CS chip select pin (low level of awaken, high level of sleep)
14	GND	Power Ground

## Application scene

- 1: 2.4G panel switch
- 2: 2.4G remote controller
- 3: 2.4G transparent transmission
- 4: Mobile phone one-to-many control
- 5: IO switching control
- 6: 2.4G toys
- 7: Application of intelligent home control

### Technical parameter

<b>Model</b>	<b>JDY-40</b>
Operating frequency range	2.4G
Transmit power	MAX 12db
Working temperature	-40°C - 80°C
Reception sensitivity	-97db
Transmission distance	120meters
TX current	40mA
RX current	24mA
Sleep current	5uA
Communication interface	Standard TTL serial port

### Dimensional drawing

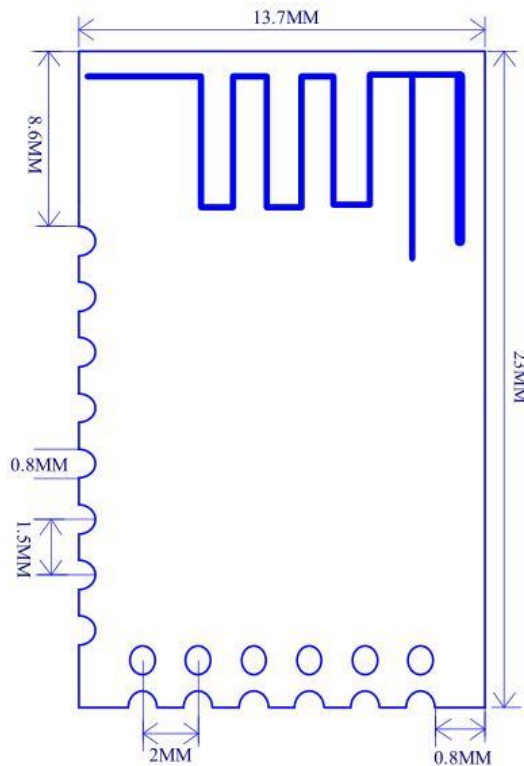

### Default configuration

Sequence	Function	Parameter	instructions
1	Baud rate	9600	AT+BAUD
2	Wireless ID	8899	AT+RFID8899
3	Device ID	1122	AT+DVID1122
4	Channel	001	AT+RFC001
5	Transmit power	12db	AT+POWE9
6	Device type	A0	AT+CLSSA0

### AT instruction set

Sequence	instructions	Effect	Default
1	AT+BAUD	Baud rate	9600
2	AT+RFID	Wireless ID	8899
3	AT+DVID	Device ID	1122
4	AT+RFC	Channel(128 Channels)	001
5	AT+POWE	Transmit power	+10db
6	AT+CLSS	Type	A0

### AT instruction instructions

In particular, the JDY-40 module sends the AT instruction need to end the symbol \r\n

#### Setting / query - baud rate

Instruction	Response	Parameter
AT+BAUD<Param>	OK	Param(1-7) 1:1200 2:2400 3:4800 4:9600
AT+BAUD	+BAUD=<Param>	5:14400 6:19200 Default Value: 4

#### RFID Setting / query - RFID

Instruction	Response	Parameter
AT+RFID<Param>	OK	Param(0000-FFFF)
AT+RFID	+BAUD=<Param>	Default Value:8899

#### Setting / query - DVID

Instruction	Response	Parameter
AT+DVID<Param>	OK	Param(0000-FFFF)
AT+DVID	+BAUD=<Param>	Default Value:8899

#### RFID Setting / query - RFC

Instruction	Response	Parameter
AT+RFC<Param>	OK	Param(001-128)
AT+RFC	+RFC=<Param>	Default Value:001

**POWESetting / query - POWE**

Instruction	Response	Parameter
AT+POWE<Param>	OK	Param(0-9) 0: -25db 1: -15db 2: -5db 3: 0db 4: +3db 5: +6db 6: +9db 7: +10db 8: +10db 9: +12db
AT+POWE	+POWE=<Param>	

**Setting / query – CLSS type**

Instruction	Response	Parameter
AT+CLSS<Param>	OK	Param A0: Serial port transparent transmission(Transceiver) C0: Remote controller or IO key indicator light(Transmitting terminal) C1: remote controller or IO key without indicator light (Transmitting terminal) C2:IO is low level at normal level, high level after receiving signal and low level after delay 30mS C3:IO is high level at normal level, low level after receiving signal and high level after delay 30mS C4:IO is low level at normal level, receives pressed signal of high level and receives lift signal low level C5: The IO level is reversed when IO receives the pressed signal. Default Value:A0
AT+CLSS	+CLSS=<Param>	

## JDY-40 application wiring diagram

### Serial port transparent transmission application circuit diagram

It can be applied to MCU and MCU wireless serial port transparent transmission, instrument and electronic toys.

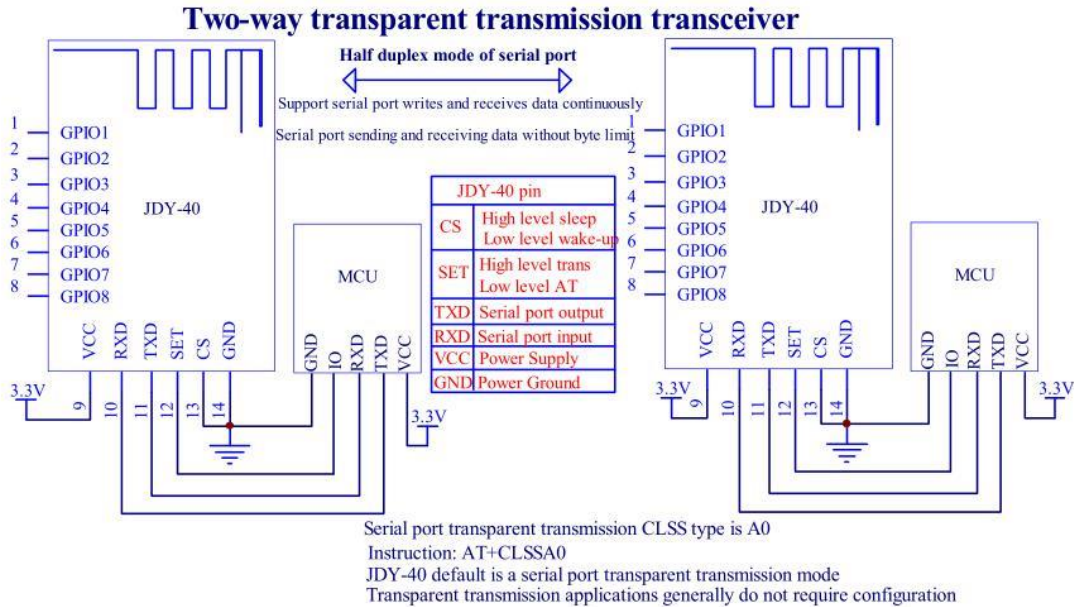

## Mobile phone one-to-many control

It can be applied to mobile phone one-to-many control, mobile phone one-to-many transparent transmission, mobile phone one-to-many application of intelligent furniture control.

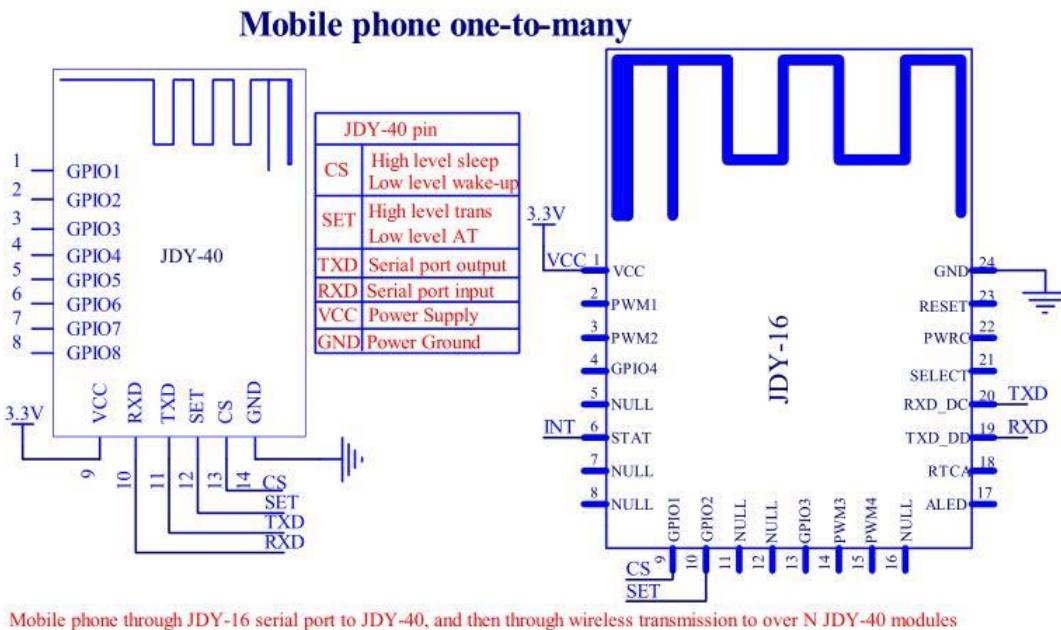

## Switching control 1

It can be applied to: the 2.4G remote controller with 8 IO can be applied to the remote control key and support the low function, two 7th batteries can be used for at least one year, application of low power consumption switch panel in intelligent home, and 2.4G toy application.

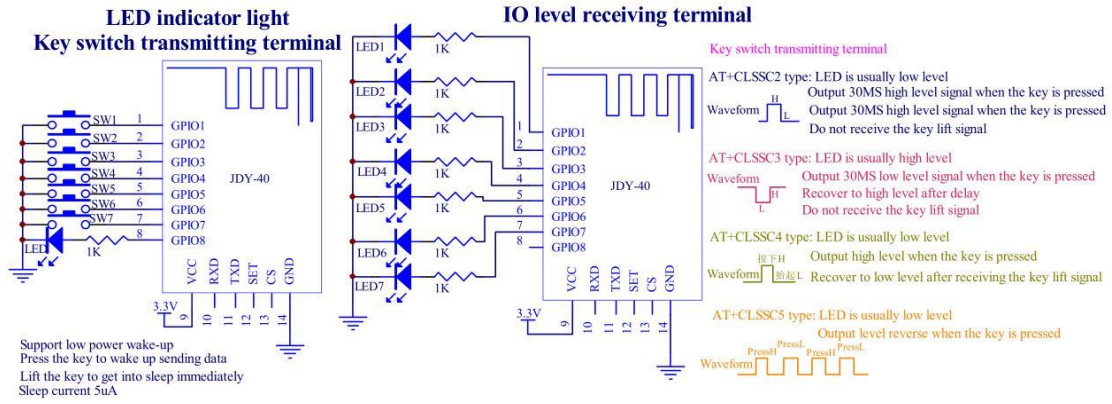

## Switching control 2

It can be applied to: the 2.4G remote controller with 7 IO can be applied to the remote control key and support the low function, two 7th batteries can be used for at least one year, application of low power consumption switch panel in intelligent home, and 2.4G toy application.

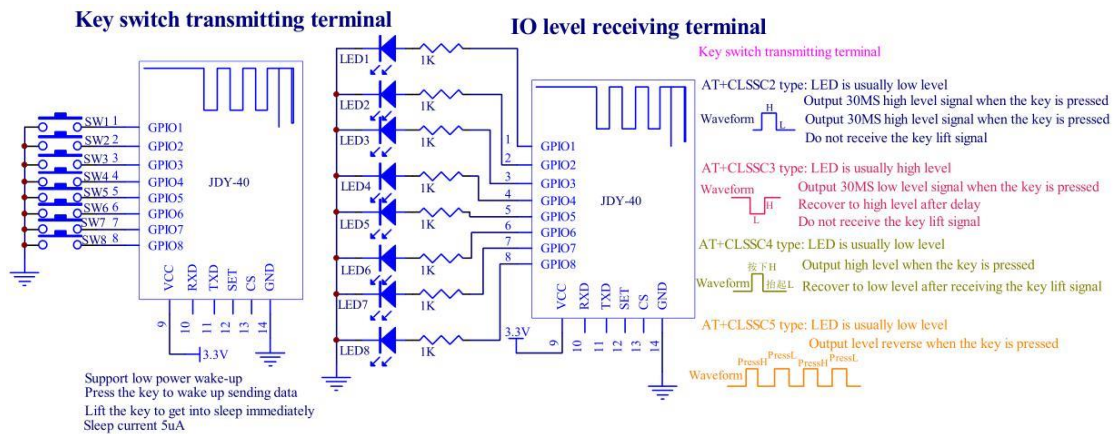

### Switching control 3

It can be applied to: the 2.4G remote controller with 8 IO can be applied to the remote control key and support the low function, two 7th batteries can be used for at least one year, application of low power consumption switch panel in intelligent home, and 2.4G toy application.

