

1 Board dimensions (top view)
Scale 5:1

2 Connector callouts (bottom view)
Scale 5:1

3 Isometric view
Scale 5:1

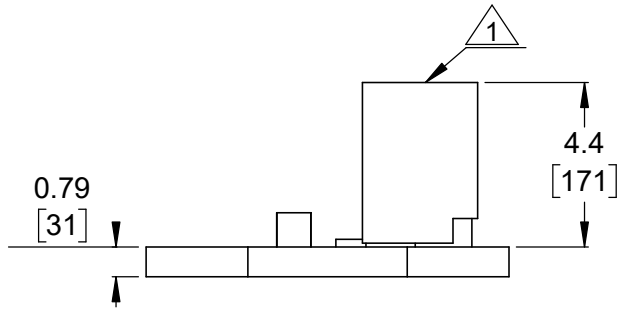

4 Profile
Scale 5:1

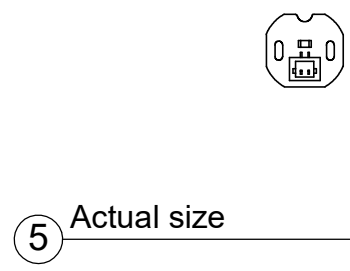

5 Actual size
Scale 1:1

1. Back-entry, 2-pin male JST SH-type connector.

2. To get the specified scale, select 100% in print settings.

3. Drill location tolerance: ± 0.1 [± 5].

4. Board edge tolerance: ± 0.3 [± 10].

https://www.pololu.com/product/5096		Item number: 5096, 5097	
Name: JST SH-Style Connector Board for Micro Metal Gearmotors, 2-Pin, Back- Entry		Dev code: con02a	
Drawing date: 21 March 2025		Material: mixed	
Units: mm [mil]		© 2025 Pololu Corporation	



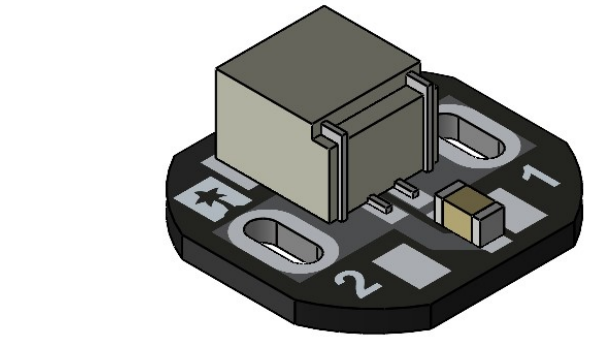
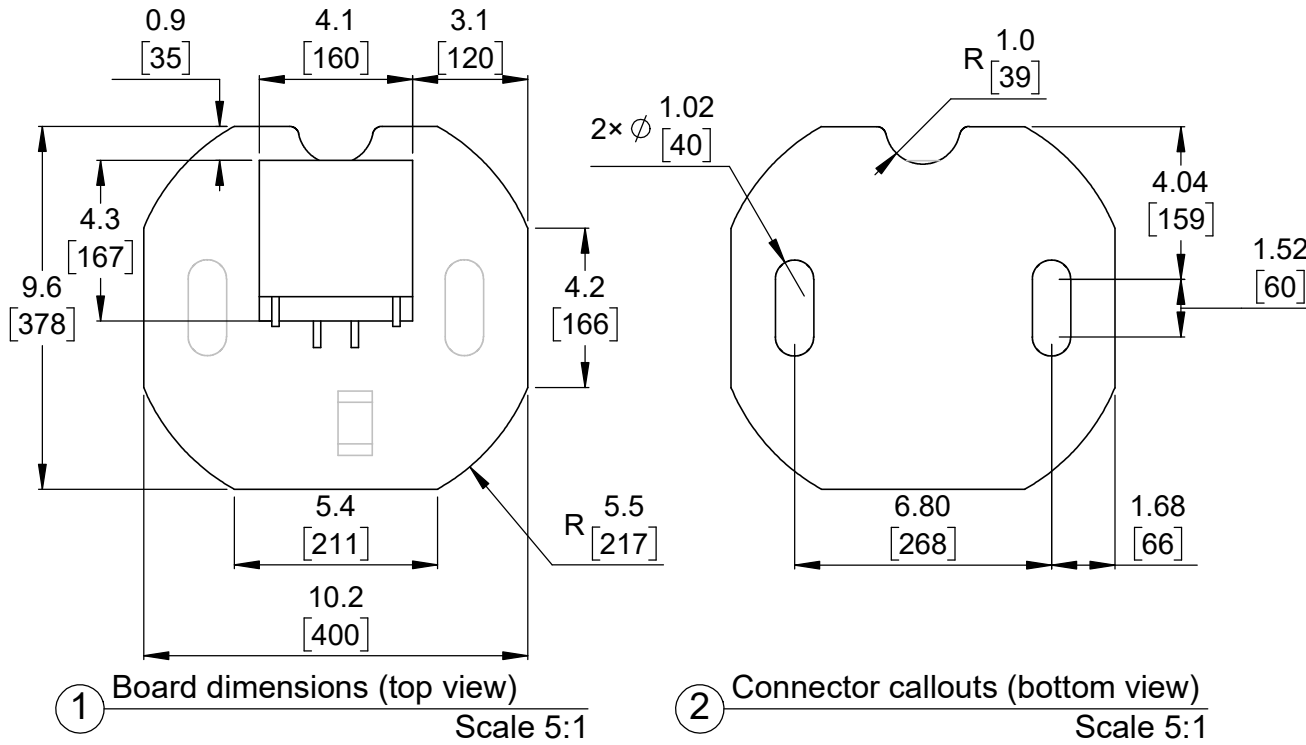

③ Isometric view Scale 5:1

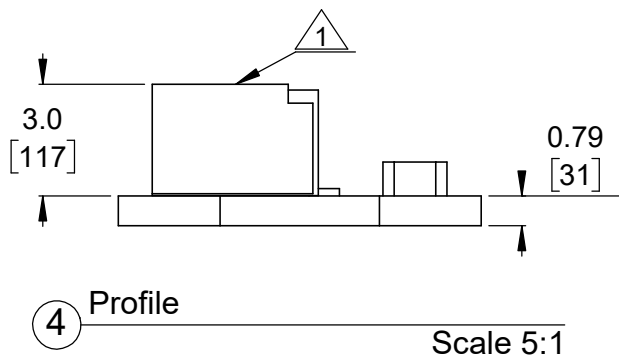

⑤ Actual size Scale 5:1

1. Side-entry, 2-pin male JST SH-type-connector.

2. To get the specified scale, select 100% in print settings.
3. Drill location tolerance: ± 0.1 [± 5].
4. Board edge tolerance: ± 0.3 [± 10].

<https://www.pololu.com/product/5098>

Name: JST SH-Style Connector Board for Micro Metal Gearmotors, 2-Pin, Side- Entry		Item number: 5098, 5099
Drawing date: 21 March 2025	Dev code: con02a	 © 2025 Pololu Corporation
Units: mm [mil]	Material: mixed	