

1. Introduction:

This is a DC 12V Ultrasonic Suspension Electronic Soldering DIY Kit. The suspending device operates at a frequency of 40KHZ in the air and can capture light objects with a density of 2-3MM, such as foam balls. It is a very interesting DIY electronic product which enables users to understand the circuit more clearly and learn soldering skills.

2. Feature:

1. Ultrasonic Suspension: Its two ultrasonic transmitters transmit 40KHz frequency to each other, which can capture light objects with a diameter of 2-3MM, such as foam balls. It is mainly used to learn and understand the principle of ultrasonic standing wave suspension.
2. Usage Method: Clamp the small foam ball with tweezers, gently place the foam ball between the two ultrasonic probes, and the foam ball will be suspended.
3. Working Principle: It refers to the Resonant Tank distance between the ultrasonic transmitter and the transmitter. During operation, the emitted and reflected waves continuously overlap to form a standing wave. The acoustic force received by the object at the standing wave node overcomes the effect of gravity and ultimately achieves the effect of suspension.
4. Electronic Circuit: It consists of a simple circuit, which is very suitable for electronic beginners to learn circuit principles and become familiar with components, such as learning education, and demonstrating the working results of the circuit through experimental effects.
5. .DIY Hand Soldering: It's a DIY kit which comes with various components. User need to install each component by hand. It can exercise and improve soldering skills, but also increase the interest in electronic technology. Great for electronics hobbyists, beginners, school and home education.

3. Parameter:

Item name: DC 12V Ultrasonic Suspension Electronic Soldering DIY Kit 2.

Work voltage: DC 12V

Work current:0.5A-1A

Diameter of suspended solids: 2~3mm

Work Temperature:-20°C~85°C 6>.Work

Humidity:0%~95%RH

Size(Installed):44*40*66mm

4. Component listing:

NO.	Component Name	PCB Marker	Parameter	QTY
1	Electrolytic Capacitor	C3	33uF~100uF	1
2	DC-005 Power Socket	J1		1
3	Monolithic Capacitor	C1,C2	0.1uF 104	2
4	Metal Film Resistor	R1	4.7K	1
5	3mm Red LED	D1		1
6	AMS1117-5.0 Regulator	U1	SOT-223	1
7	STC15F104W	U2	SOP-8	1
8	TC4427 Driver	U3	SOP-8	1
9	Ultrasonic Transmitter		T	2
10	M2*4mm Screw			4
11	M2*7mm Copper Pillar			2
12	M2*39+3mm Copper Pillar Screw			2

13	M3*6mm Screw		4
14	M3*15mm Nylon Pillar		4
15	Foam Ball		5
16	Main PCB		1
17	TOP PCB		1
Note:Users can complete the installation according to the PCB silk screen and component list.			

5. Note:

1. Must use light and small suspended solids, otherwise they cannot be suspended.
2. .The ultrasonic emitter is very sensitive to vibration, so avoid falling/collision, etc. After the probe is soldering, the excess metal pins can not be cut off.

6. Installation Tips:

- 1>.User needs to prepare the soldering tool at first.
- 2>.Please be patient until the installation is complete.
- 3>.The package is DIY kit. It need finish install by user.
- 4>.The soldering iron can't touch the components for a long time(1.0 second), otherwise it will damage the components.
- 5>.Pay attention to the positive and negative of the components.
- 6>.Strictly prohibit short circuit.
- 7>.Install complex components preferentially.
- 8>.Make sure all components are in right direction and right place.
- 9>.Please wear anti-static gloves or anti-static wristbands when installing electronic components.
- 10>.It is strongly recommended to read the installation manual before starting installation!!!

7. Schematic:

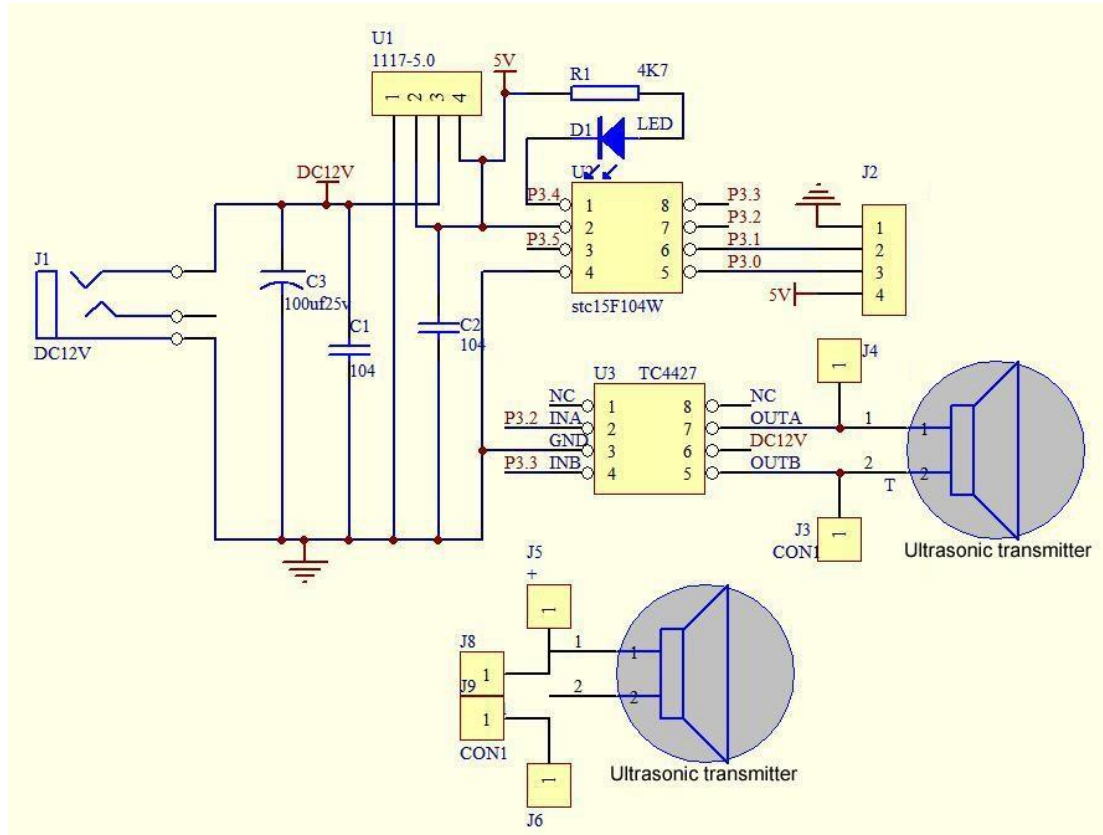

8. Installation Steps:

- 1>.Step 1: Install 1pcs SMD components SOP-8 STC15F104W at U2. There is a white gap on PCB silk screen at U2 and there is a mark(dot) on IC. These two marks are corresponding to each other and

are used to specify the installation direction.

2>.Step 2: Randomly choose a pad on the PCB, and then melt the solder on this pad.

3>.Step 3: Fix STC15F104W:

3.1. Use a soldering iron to melt tin on the pad just now and hold IC with tweezers in the other hand to place/press on U2 to prevent movement.

3.2. Take care to match and align each pins to pads.

3.3. Then remove soldering iron after align pins.

3.4. Then remove tweezers after solder tin cooling and solidification.

4>.Step 4: Connect others pads on STC15F104W to pads on PCB by tin and soldering iron. Tips for one method:

4.1>.Use a large amount of solder tin to cover all pads.

4.2>.Make sure all pins and pads are covered with tin.

4.3>.Use a soldering iron to keep the tin in the melting state. At the same time, use a solder sucker or Desoldering Braid to remove the excess solder.

5>.Step 5: Install 1pcs SMD components SOP-8 TC4427 Driver at U3 by the same method.

6>.Step 6: Install 1pcs SMD components SOT-223 AMS1117-5.0 Regulator at U1 by the same method.

7>.Step 7: Install 1pcs 4.7K Metal Film Resistor at R1.

8>.Step 8: Install 2pcs 0.1uF 104 Monolithic Capacitor at C1,C2.

9>.Step 9: Install 1pcs 3mm Red LED at D1. Note: The longer pin is positive pole and connect to ' + ' pad.

10>.Step 10: Install 1pcs DC-005 Power Socket at J1.

11>.Step 11: Install 1pcs 33uF~100uF Electrolytic Capacitor at C3. Note: The longer pin is positive pole and connect to ' + ' pad.

12>.Step 12: Install 1pcs Ultrasonic Transmitter at T on PCB another side. Note: It is positive pole which the pin has a bigger black mark, that need connect to ' + ' pad. It is not recommended to cut off excess metal pins to avoid damaging the transmitter.

13>.Step 13 Install 1pcs Ultrasonic Transmitter at T on another smaller PCB. Note: It is positive pole which the pin has a bigger black mark, that need connect to ' + ' pad. It is not recommended to cut off excess metal pins to avoid damaging the transmitter.

14>.Step 14: Splices M2*7mm Copper Pillar and M2*39+3mm Copper Pillar Screw to 46mm Copper Pillar.

15>.Step 15: Fix 4pcs M3*15mm Nylon Pillar on the bigger PCB by 2pcs M2*4mm Screw.

16>.Step 16: Fix 2pcs spliced 46mm Copper Pillar on the bigger PCB.

17>.Step 17: Fix the smaller PCB by 2pcs M2*4mm Screw. Note that the positive electrodes of the two PCB correspond to each other.

9. Installation Shown Steps:

Step 1: Install 1pcs SMD components SOP-8 STC15F104W at U2.
There is a white gap on PCB silk screen at U2 and there is a mark(dot) on IC.
These two marks are corresponding to each other and are used to specify the installation direction.

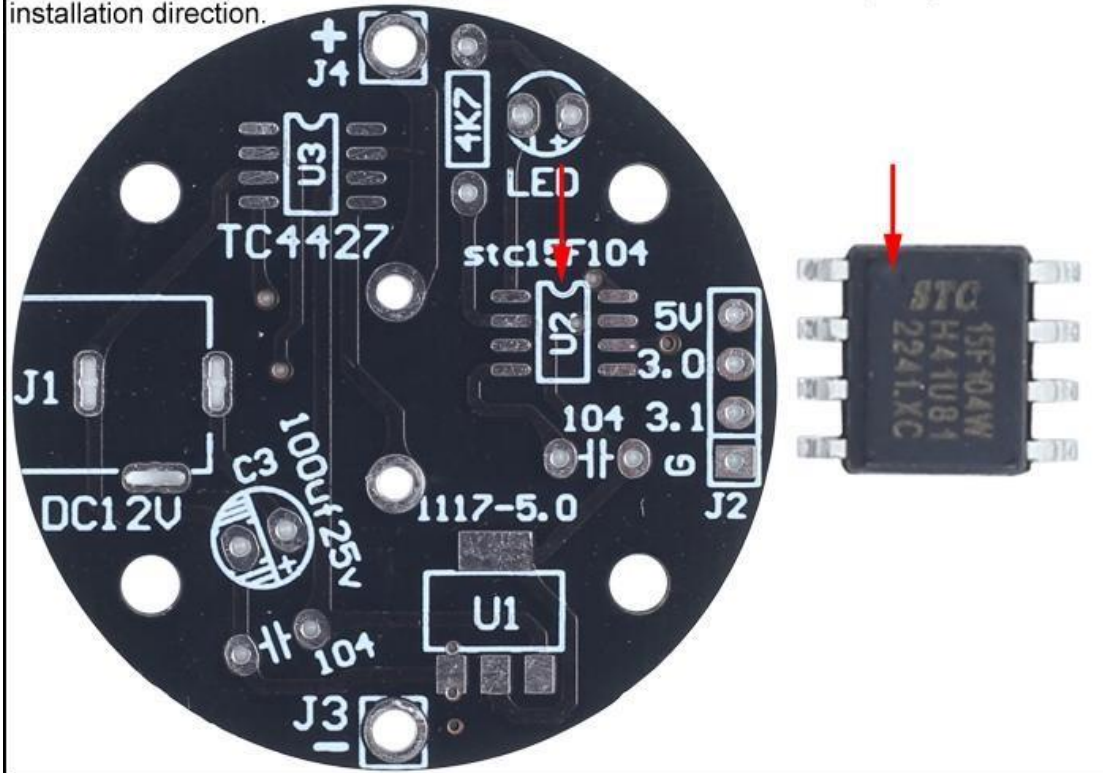

Step 2: Randomly choose a pad on the PCB, and then melt the solder on this pad.

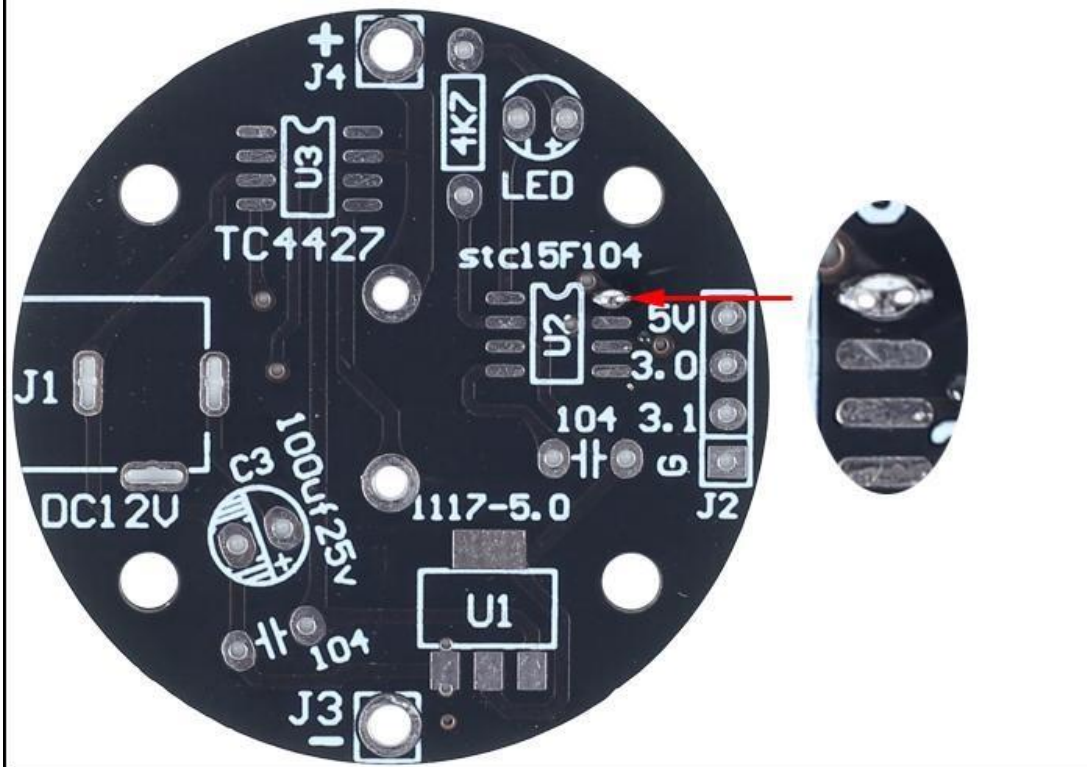

Step 3: Fix STC15F104W:

- 3.1. Use a soldering iron to melt tin on the pad just now and hold IC with tweezers in the other hand to place/press on U2 to prevent movement.
- 3.2. Take care to match and align each pins to pads.
- 3.3. Then remove soldering iron after align pins.
- 3.4. Then remove tweezers after solder tin cooling and solidification.

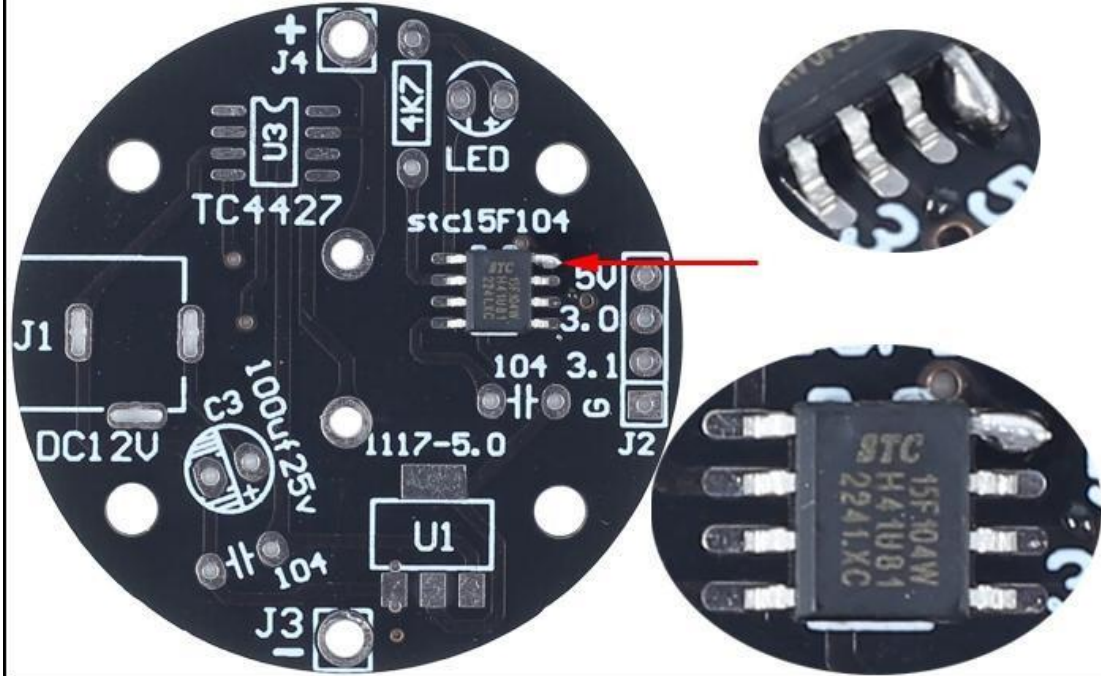

Step 4: Connect others pads on STC15F104W to pads on PCB by tin and soldering iron. Tips for one method:

- 4.1>. Use a large amount of solder tin to cover all pads.
- 4.2>. Make sure all pins and pads are covered with tin.
- 4.3>. Use a soldering iron to keep the tin in the melting state. At the same time, use a solder sucker or Desoldering Braid to remove the excess solder.

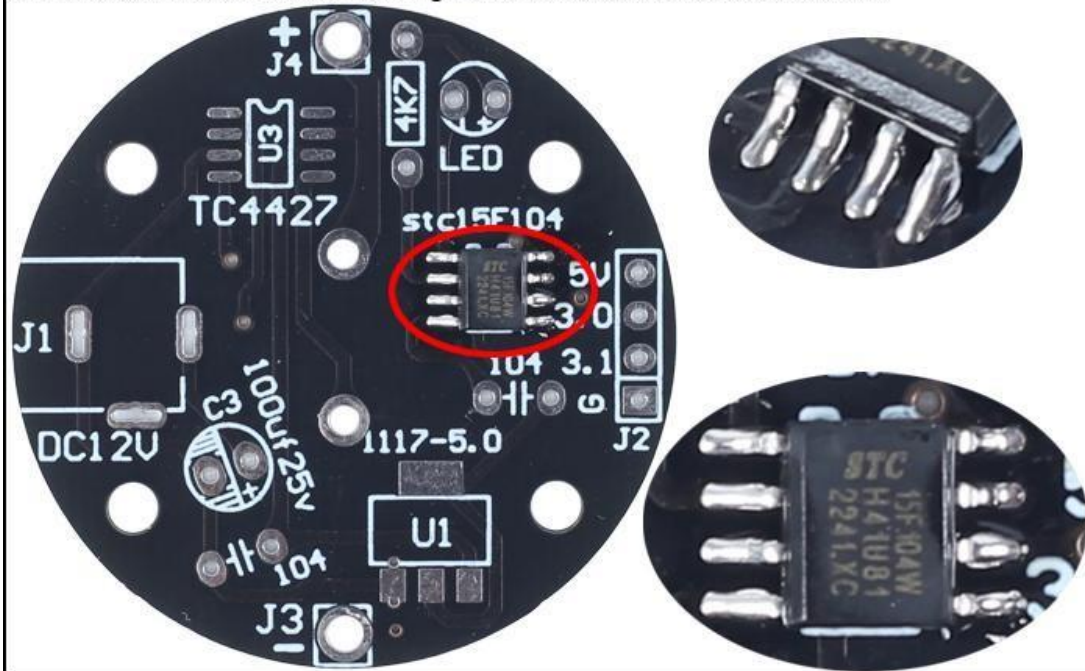

Step 5: Install 1pcs SMD components SOP-8 TC4427 Driver at U3 by same method.

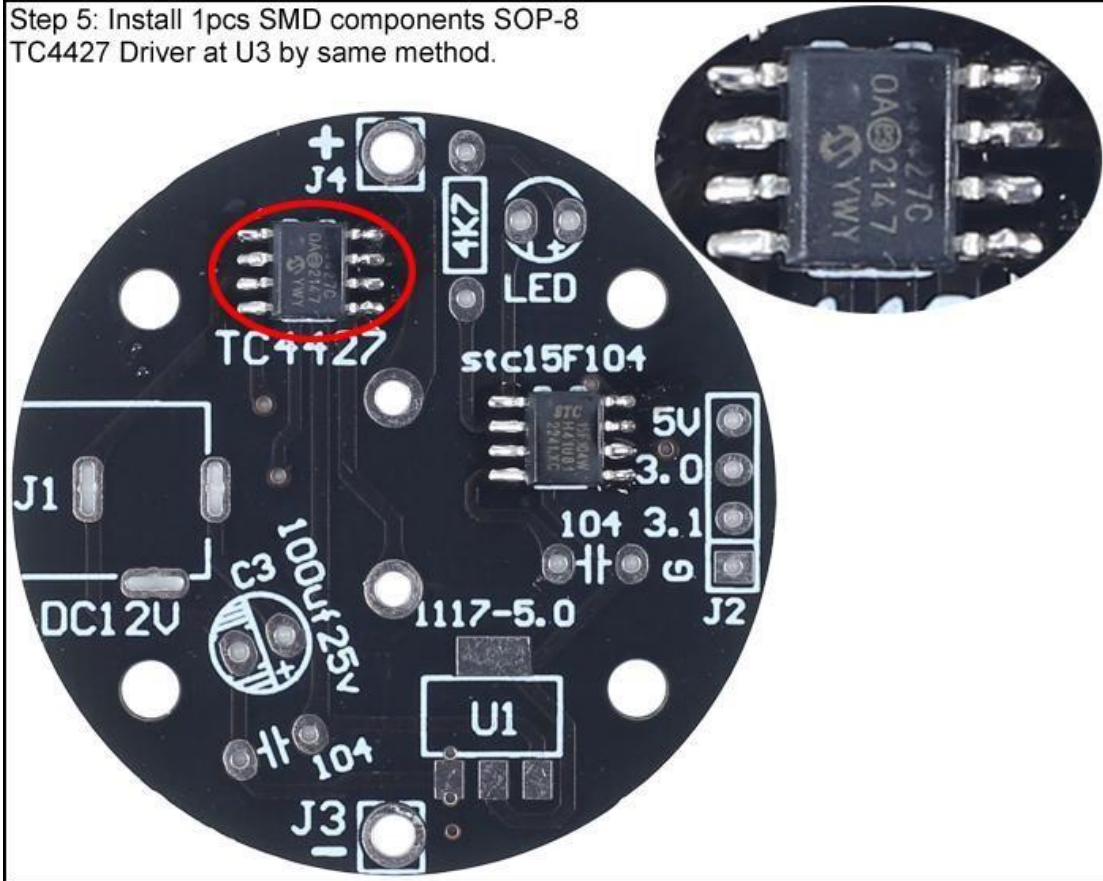

Step 6: Install 1pcs SMD components SOT-223 AMS1117-5.0 Regulator at U1 by the same method.

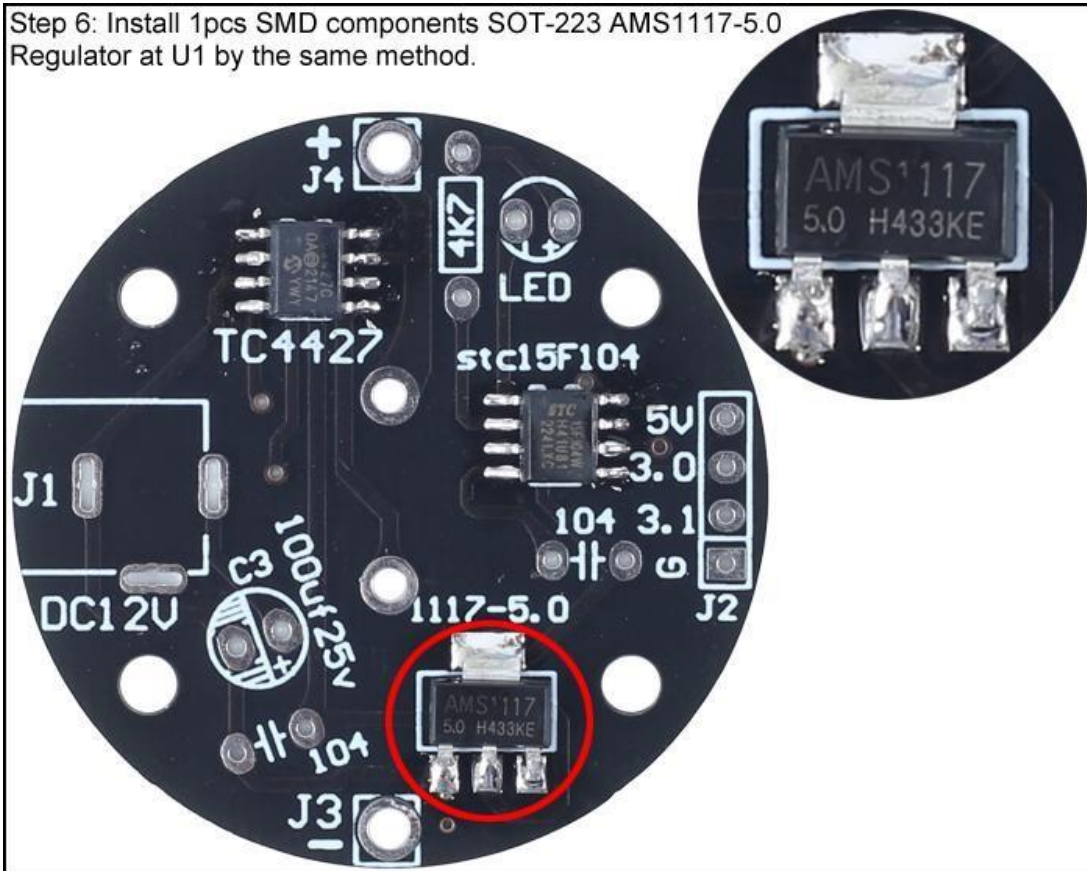

Step 7: Install 1pcs 4.7K Metal Film Resistor at R1.

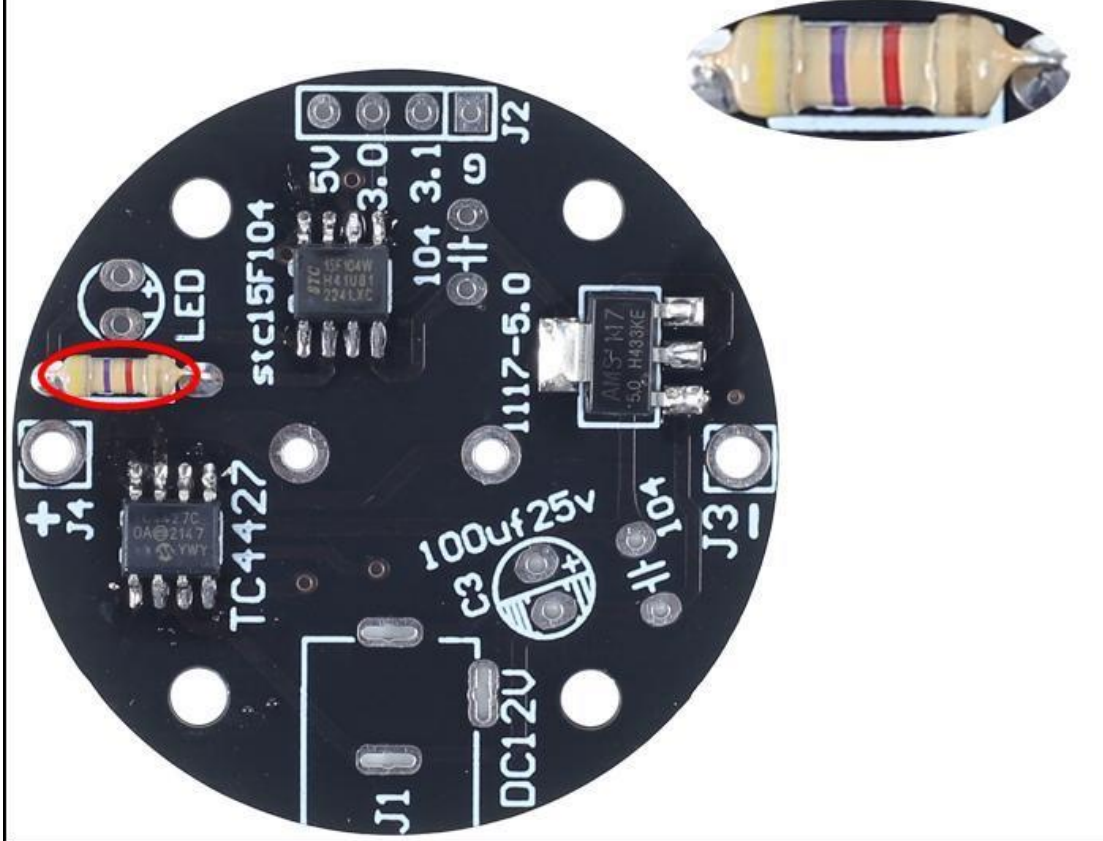

Step 8: Install 2pcs 0.1uF 104 Monolithic Capacitor at C1,C2.

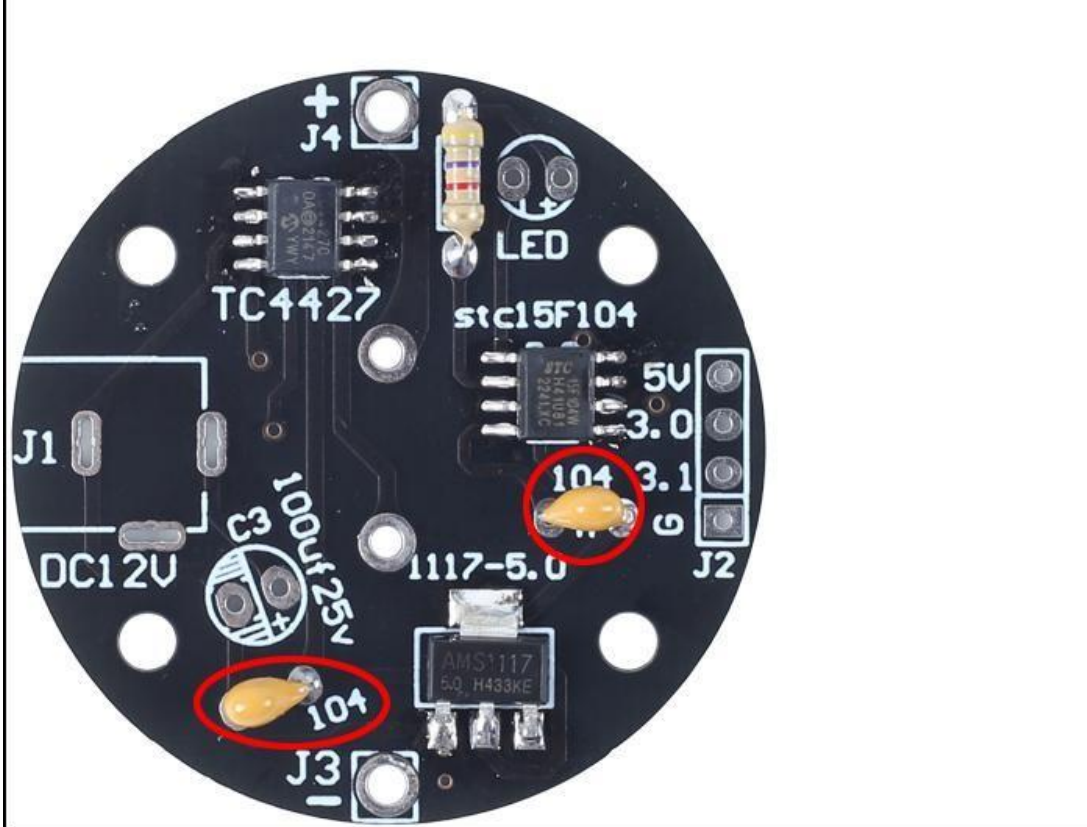

Step 9: Install 1pcs 3mm Red LED at D1. Note: The longer pin is positive pole and connect to '+' pad.

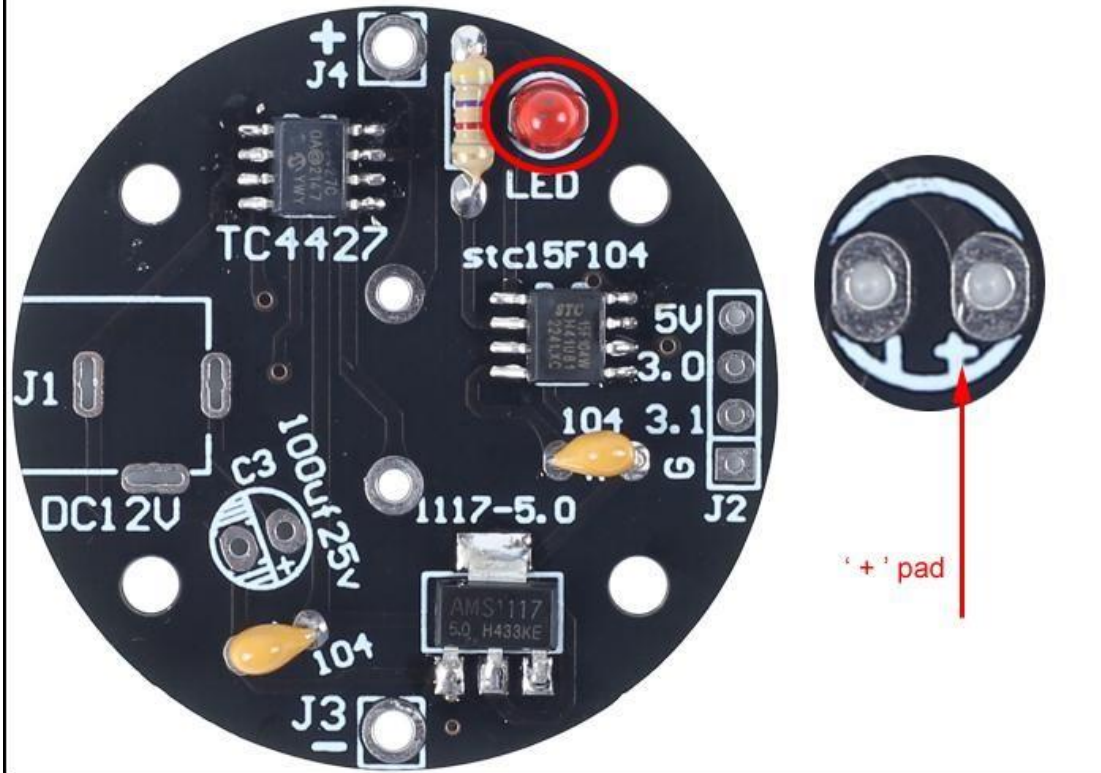

Step 10: Install 1pcs DC-005 Power Socket at J1.

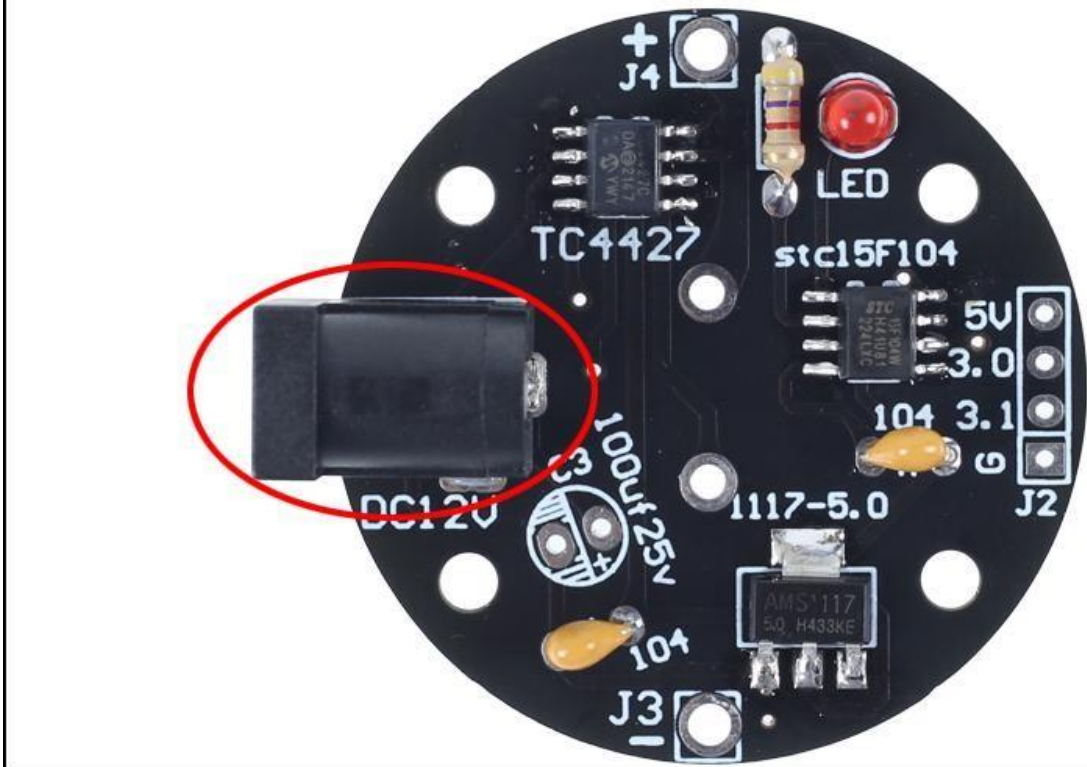

Step 11: Install 1pcs 33uF~100uF Electrolytic Capacitor at C3.
 Note: The longer pin is positive pole and connect to '+' pad.

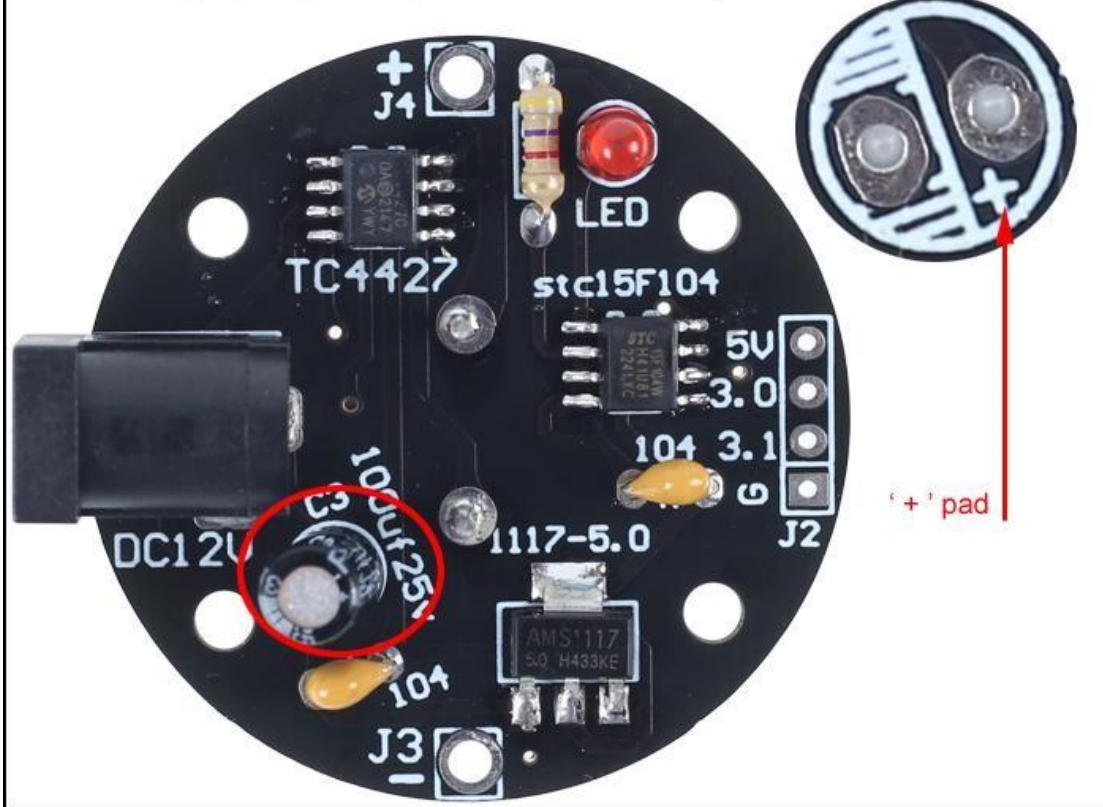

Step 12: Install 1pcs Ultrasonic Transmitter at T on PCB another side. **Note:** It is positive pole which the pin has a bigger black mark, that need connect to '+' pad. It is **not** recommended to cut off excess metal pins to avoid damaging transmitter.

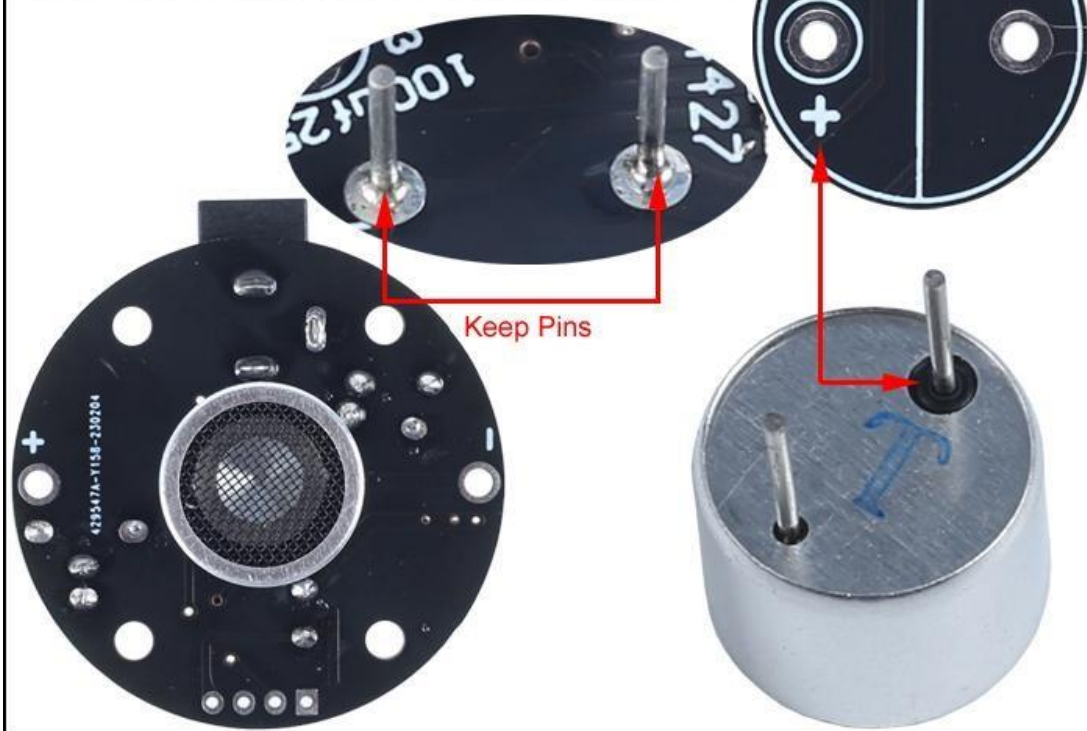

Step 13 Install 1pcs Ultrasonic Transmitter at T on another smaller PCB.

Note: It is positive pole which the pin has a bigger black mark, that need connect to '+' pad.

It is **not** recommended to cut off excess metal pins to avoid damaging the transmitter.

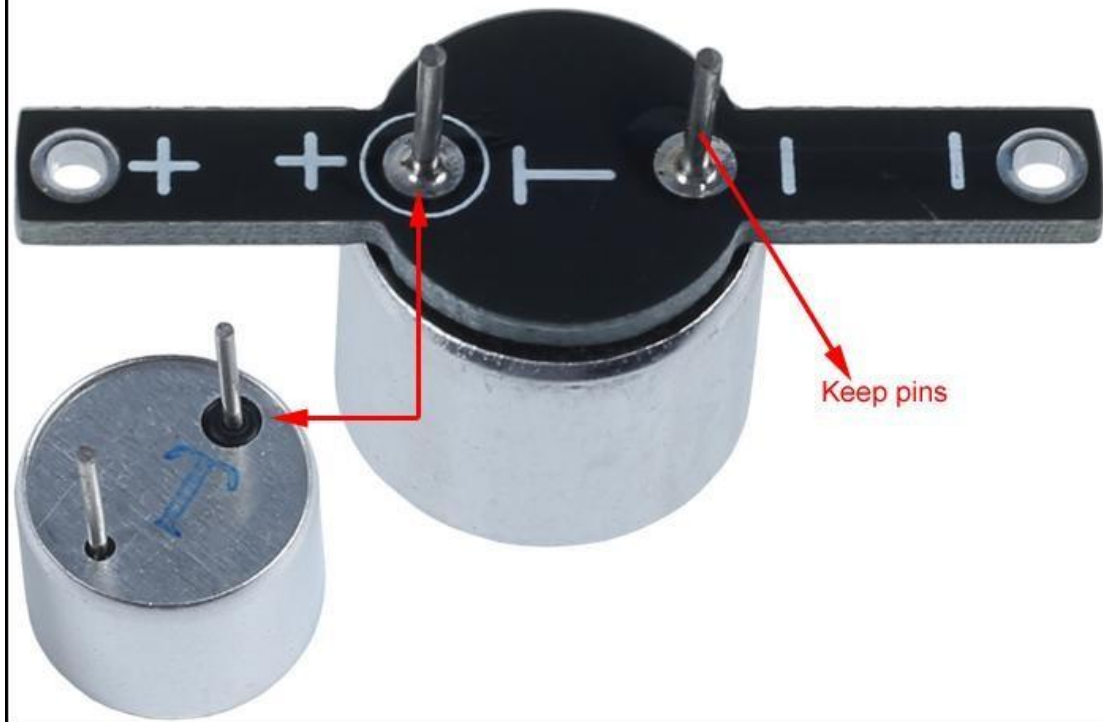

Step 14: Splices M2*7mm Copper Pillar and M2*39+3mm Copper Pillar Screw to 46mm Copper Pillar.

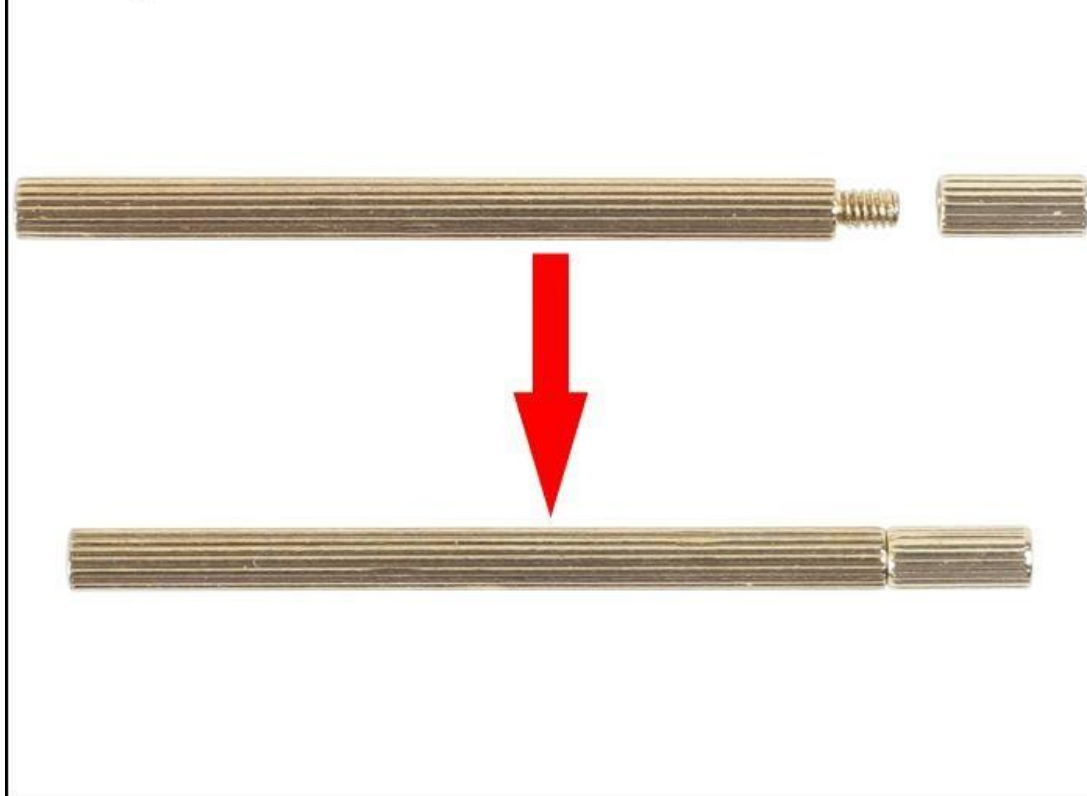

Step 15: Fix 4pcs M3*15mm Nylon Pillar on the bigger PCB by 2pcs M2*4mm Screw.



Step 16: Fix 2pcs spliced 46mm Copper Pillar on the bigger PCB.



Step 17: Fix the smaller PCB by 2pcs M2*4mm Screw.
Note that the positive electrodes of the two PCB correspond to each other.

