

RoHS Compliant

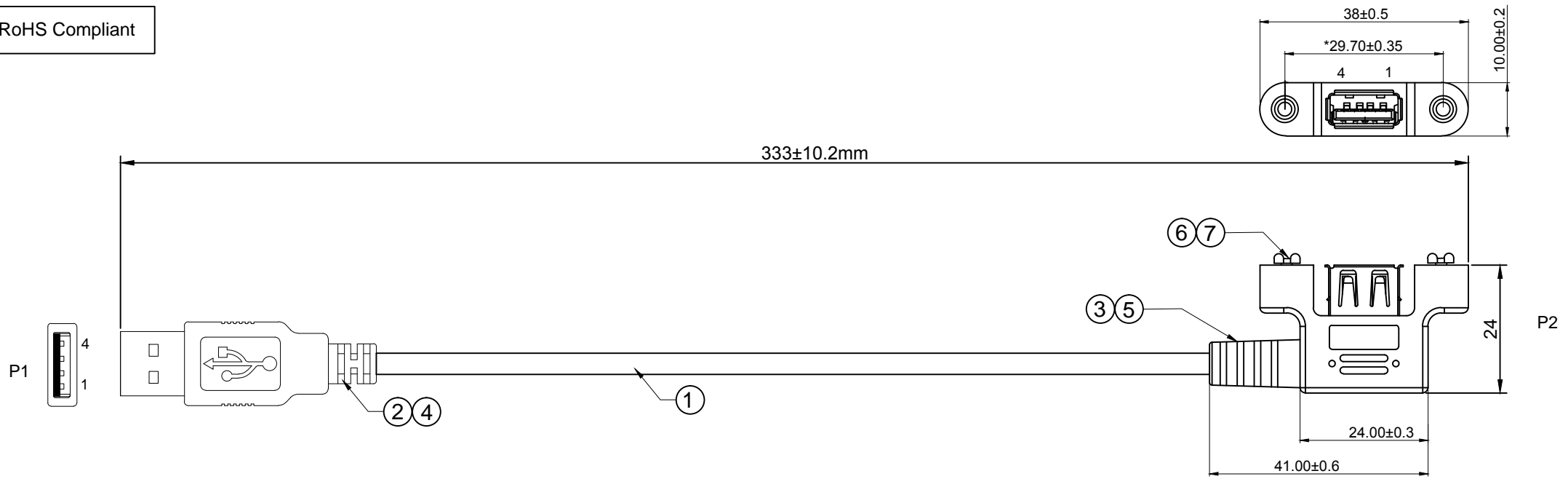

PIN OUT:

P1		P2
1-----		1
2-----	8	2
3-----		3
4-----		4
S-----		S

NOTES:

1. PIN ASSIGNMENT SEE TO WIRE LIST.
2. ELECTRICAL TEST CONDITION:
  - (a). 100% OPEN, SHORT & MISWIRE TEST,
  - (b). INSULATOR RESISTANCE: 10 Mohm MIN.  
DC 300V 0.01sec.
  - (c). CONTACT RESISTANCE: 3ohm MAX.

7	SCREW: 5*11mm M3 .	
6	NUT: 5.5*5mm M3 .	
5	PVC 27P BLACK .	
4	PVC 45P BLACK .	
3	USB 2.0 A F WHITE PBT WITH NICKLE PLATED SHELL.	
2	USB 2.0 A M WHITE PBT WITH NICKLE PLATED SHELL.	
1	24AWG*2C+28AWG*1P+AEB OD:4.5MM L:333mm BLACK PVC JACKET UL2725.	
NO.	Description	P/N

DWG NO:	PCM-0238	GOODS CODE		Draw	Jason	Date	2020/5/26
ITEM NO.		DRAWING EVIDENCE		Check		Date	
Goods NO.				Approval		Date	
Original NO.		Unit(mm)					

PREMIER CABLE MFG CO LTD

D		
C		
B		
VER.A	REVISE	Date.