

DICE KIT

Technical Manual

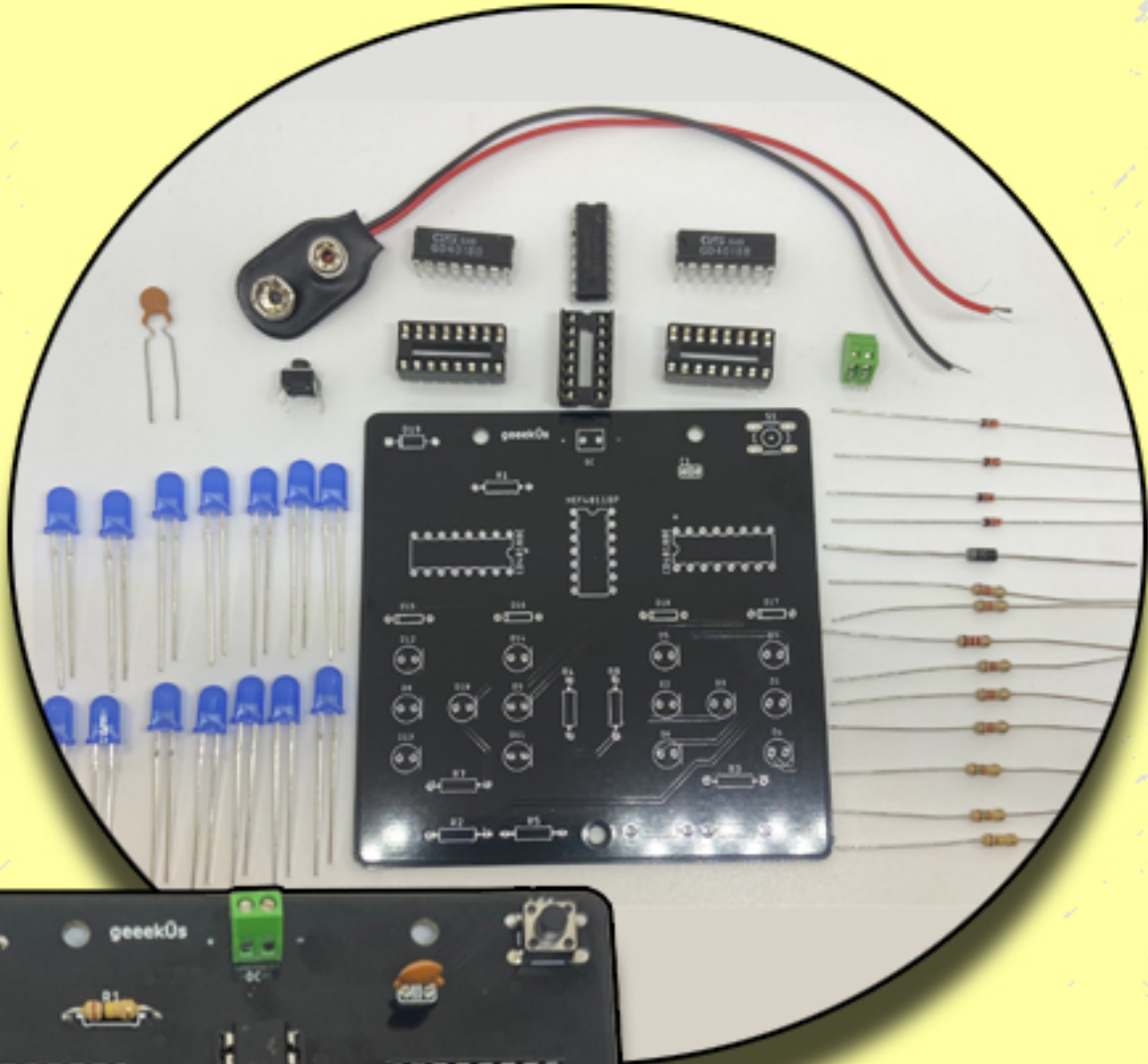

GK-EK-DICE

Table of Contents

Components List.....	3
Identification of Parts.....	3
Identification of Capacitance.....	4
Identification of Resistance.....	4
How to Play Basic <i>Craps</i>	5
Guide to Using the Board.....	6
PCB Overview.....	7
Circuit Schematic.....	8

Components List

1x CD4011BE IC Chip

2x GD4018B IC Chips

1x Tactile Switch

1x 1N4004 diode

9x Resistors (R2, R3, R5, R6, R7, R9: 1.2k Ω), (R4, R8: 1.5k Ω), (R1: 100k Ω)

14x LEDs

1x 14-DIP Socket

2x 16-DIP Sockets

1x Ceramic Capacitor (0.01 μ F)

4x 1N4148 diodes

1x 9V Battery

1x Screw Terminal

Push Button



Diode



Capacitor



IC Socket



IC Chip

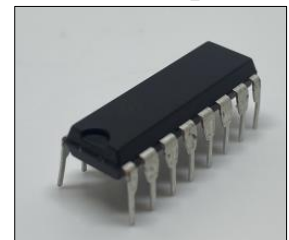

Identification of Parts

LED



Resistor



Screw Terminal



Identification of Capacitance

Electrolytic capacitors can be identified if they possess a positive and a negative polarity. It is important to know which polarity is which because if a capacitor gets soldered incorrectly, it will heat up and potentially explode. The negative polarity can be identified with the shorter pin of the capacitor, but if that's insufficient, look for the polarity marking on it.



Ceramic capacitors, however, do not have polarity. The first two numbers indicate the first and second digit of the value while the third number is its multiplier: 1 – 10, 2 – 100, 3 – 1K, and so on.

0.01 μ F Capacitor \rightarrow
(or 10,000pF)



Identification of Resistance

The following image serves as a guide to identify the value of the resistor:

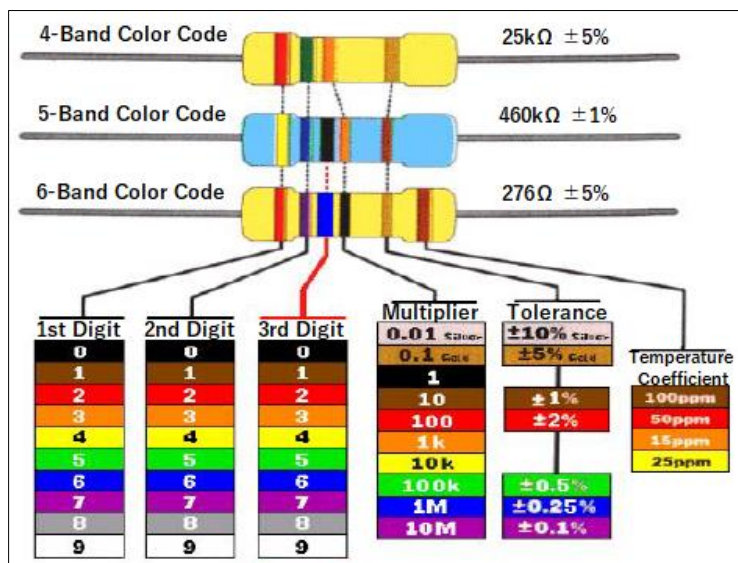

How to Play Basic *Craps*

Craps is a gambling game involving a minimum of two players where they bet on a number and attempt to roll it, except there is some additional complexity.

The game starts on the first betting round. During the beginning of each betting round, a player rolls the dice (Shooter) to assert a come-out roll. One of three roll scenarios will occur: Natural, Craps, Point.

Natural occurs when the result of the roll is 7 or 11, meaning the Shooter wins and rolls the die again.

Craps occurs when the result of the roll is 2, 3 or 12, meaning the Shooter loses and rolls the die again.

Point occurs when the result of the roll is 4, 5, 6, 8, 9 or 10, meaning the Shooter must roll the same number again before they roll a 7 to win and roll again, otherwise they lose and end their betting round.

All players, including the Shooter, must place a bet to gamble what will be rolled. The game offers many types of bets, but only the following will be mentioned to keep things simple: Pass or Don't Pass, Come or Don't Come, Proposition.

Pass: Players bet the Shooter will roll a Natural.

Don't Pass: Players bet the Shooter will not roll a Natural.

Come: Players bet the Shooter will roll a Natural but lose if Craps are rolled. If Point is rolled, the number rolled becomes the bet.

Don't Come: Players bet the Shooter will not roll a Natural and win if Craps is rolled. If Point is rolled, players win if a 7 is rolled before the rolled number.

Proposition: Players bet on one of the following in hopes to win: Any Seven (7), Any Craps (2, 3, 12), Ace Deuce (3), Aces (2), Boxcars (12), Horn (2, 3, 11, 12).

The hardest bets offer the biggest wins.

Guide To Using the Board

Upon powering the board with red wire going through positive pin (+) and black through negative (-) into the DC screw terminal, the “rolling” immediately begins. The LEDs illustrate a different combination of numbers as real dice would at a rate of 60 cycles per second (one set of numbers every 16ms) with the use of logic gate systems in the IC chips. To stop the roll, the switch must be pressed and held, and the final number will be determined. Upon letting go of the button, the rolling immediately begins again.

Tips for Soldering

- ❖ Suggested soldering temperature for lead-free solder can range between 280° and 370° Celsius. Temperature exceeding the suggested maximum temperature increases the flow of solder but may burn the pad and ruin the functionality of the component, as well as reduce the lifespan of the soldering iron tip. Keep the soldering iron tinned.
- ❖ To enforce safety when soldering, keep the soldering iron away from the reach of children. Solder is a toxic substance and should not be put in the mouth. Wash hands after working with solder. Wear safety goggles/glasses when soldering.
- ❖ Apply generous amount of solder. Too little solder will not cover a connection and lead to lack of proper functionality, too much solder might cause a short with unneeded connections with other pads that pose a risk to breaking the board.
- ❖ Do not hold the soldering iron tip against the pad for too long when heated. Apply solder against the component’s pad, apply the soldering iron, watch solder flow, pull away. A good connection will be shown as a spike. If a shape of a bubble is taken, too much solder has been applied and may not have smoothly flowed into the pin. Simply apply the iron tip against the connection to fix when solder properly flows.
- ❖ Make sure you place the components correctly before soldering. The screw terminal (see next page) should be placed with the holes facing upwards (away from the rest of the PCB).

PCB Overview

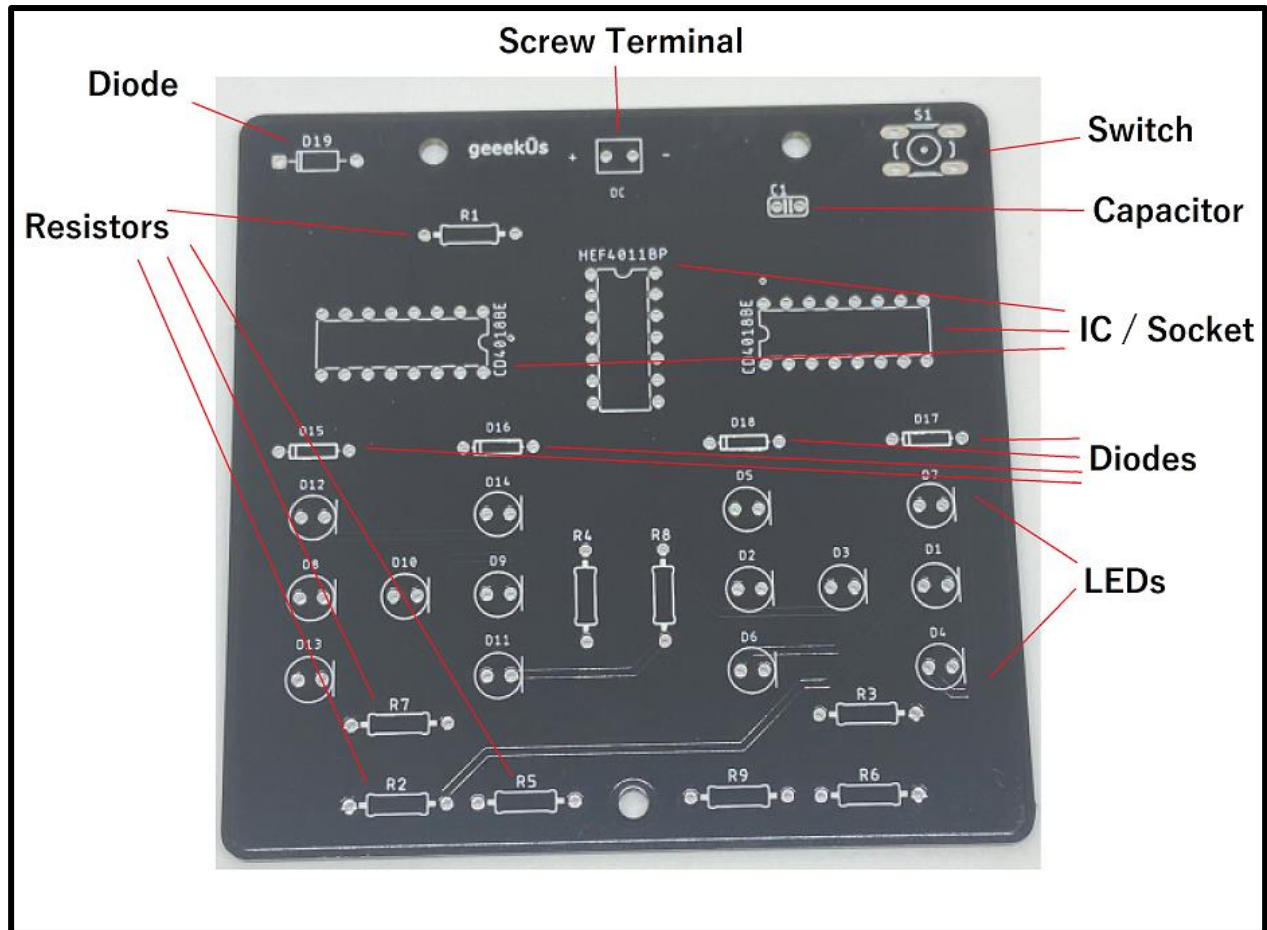

Reset Button

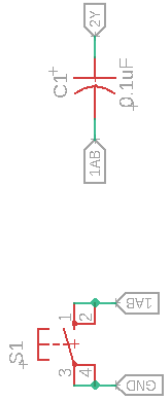

9V Battery Power Supply

Ground

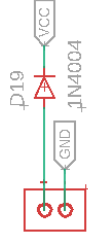

Light-Emitting Diodes (LEDs)

MCU Logic Systems

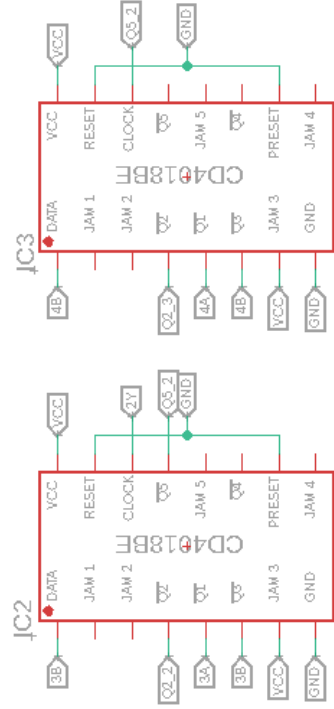
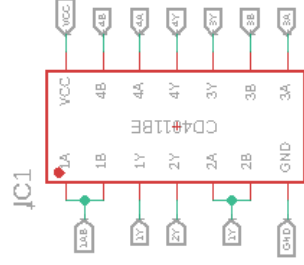
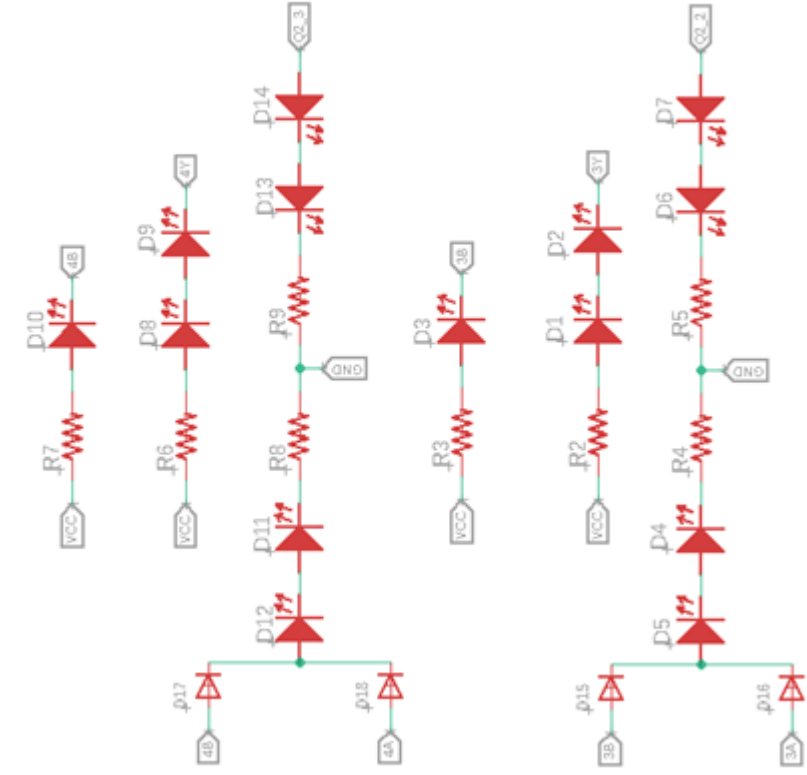

Circuit Schematic