



## LM13080 Programmable Power Op Amp

### General Description

The LM13080 is an internally compensated medium power operational amplifier designed for use in those applications requiring load currents of several hundred milliamperes. This amplifier has the added advantage of having an input stage programmed with an external resistor. The user is able to optimize the amplifier performance for each individual application with this feature. Applications include servo amplifiers and drivers, high input impedance audio amplifiers, DC-to-DC converters, precision power comparators which can either sink or source current and motor speed controls.

The LM13080 may be powered from either single or dual power supplies, and will operate from as little as 3V.

As a power operational amplifier, the LM13080 is capable of delivering 0.25A to a load. This feature allows the system designer to fulfill his medium power circuit requirements without having to add external current boost transistors to the output of a standard operational amplifier.

By selecting the proper input stage bias resistor it is possible to tailor the performance of the input stage to meet the needs of any particular system. Trade-offs between input offset voltage, input bias current and gain bandwidth are easily made.

An unusual feature of the LM13080 is an electronic shut-down capability.

### Features

- High output current—250 mA
- Externally programmable input stage
- Low power supply operation—3V
- Electronic shut-down capability
- Internally compensated for unity gain
- Low input bias current

### Schematic Diagram

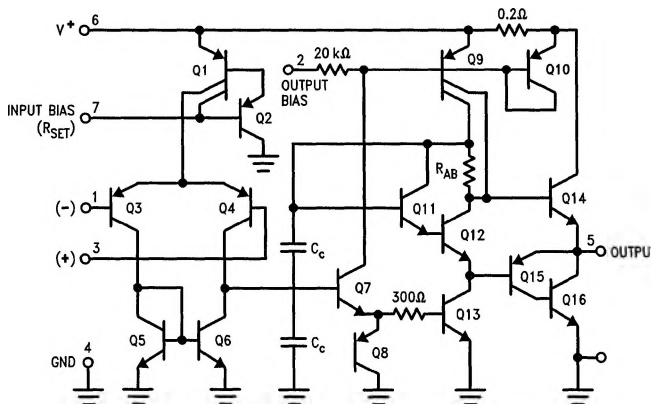

TL/H/7978-2

### Connection Diagram

Order Number LM13080N  
See NS Package Number N08E

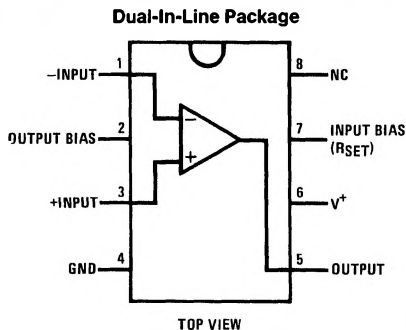

TOP VIEW

TL/H/7978-1

## Absolute Maximum Ratings

If Military/Aerospace specified devices are required, contact the National Semiconductor Sales Office/Distributors for availability and specifications.

Supply Voltage Operation Range	3V to 15V $\pm 1.5V$ to $\pm 7.5V$
Power Dissipation (Note 1)	1250 mW
Differential Input Voltage (Note 2)	15V

Input Voltage Range (Note 3)	-0.3V to +15V
Input Current ( $V_{IN} \leq -0.3V$ ) (Note 4)	20 mA
Operating Temperature Range	0°C to +70°C
Storage Temperature Range	-65°C to +150°C
Lead Temperature (Soldering, 10 sec.)	300°C
ESD rating to be determined.	

## Electrical Characteristics $V_S = 12V, R_{SET} = 680k, 0^\circ C \leq T_A \leq 70^\circ C$ , unless otherwise specified

Parameter	Conditions	Min	Typ	Max	Units
Input Offset Voltage	$T_A = 25^\circ C$ (Note 5)		$\pm 3$	$\pm 7$	mV
Input Bias Current	$I_{IN(+)}$ or $I_{IN(-)}$ , $T_A = 25^\circ C$		100	400	nA
Input Offset Current	$I_{IN(+)} - I_{IN(-)}$ , $T_A = 25^\circ C$		$\pm 30$	$\pm 75$	nA
Supply Current	$R_L = \infty$ , $T_A = 25^\circ C$ (Note 6)		3	6	mA
Output Voltage Swing $V_{OH}$	$V_S = \pm 6V$ , $T_A = 25^\circ C$ (Note 1) $R_L = 50\Omega$	4.5	5		V
	$R_L = 8\Omega$	2			V
$V_{OL}$	$R_L = 50\Omega$		-5	-4.5	V
	$R_L = 8\Omega$			-2	V
Large Signal Voltage Gain	$V_S = \pm 6V$ , $R_L = 50\Omega$ , $f = 100$ Hz, $T_A = 25^\circ C$	3	10		V/mV
Input Common-Mode Voltage Range	$V_S \leq 15V$ , $T_A = 25^\circ C$ (Note 3)	1		$V_S - 1.5$	V
Input Offset Voltage	(Note 5)			$\pm 10$	mV
Input Offset Voltage Drift			5		$\mu V/^\circ C$
Input Bias Current	$I_{IN(+)}$ or $I_{IN(-)}$			600	nA
Input Offset Current	$I_{IN(+)} - I_{IN(-)}$			$\pm 150$	nA
Input Offset Current Drift			50		$pA/^\circ C$
Supply Current	$R_L = \infty$ (Note 6)			8	mA
Output Voltage Swing $V_{OH}$	$V_S = \pm 6V$ (Note 1) $R_L = 50\Omega$			4	V
	$R_L = 8\Omega$			1.6	V
$V_{OL}$	$R_L = 50\Omega$	-4			V
	$R_L = 8\Omega$	-1.6			V

# Electrical Characteristics $V_S = 12V, R_{SET} = 680k, 0^\circ C \leq T_A \leq 70^\circ C$ , unless otherwise specified (Continued)

Parameter	Conditions	Min	Typ	Max	Units
Large Signal Voltage Gain	$V_S = \pm 6V, R_L = 50\Omega, f = 100\text{ Hz}$	1			V/mV
Input Common-Mode Voltage Range	$V_S \leq 15V$ (Note 3)	1.25		$V_S - 1.75$	V
Common-Mode Rejection Ratio	$T_A = 25^\circ C$	63	85		dB
Total Harmonic Distortion	$R_L = 8\Omega, V_O = 2\text{ Vrms}, f = 1\text{ kHz}, T_A = 25^\circ C$		0.5	5	%

**Note 1:** For operation at high temperatures, the LM13080 must be derated based upon a maximum junction temperature of  $150^\circ C$  and a thermal resistance of  $100^\circ C/W$ . The thermal resistance values given are for a still air ambient with the package soldered into a printed circuit board.

**Note 2:** Differential input voltages up to the magnitude of the power supply voltage will not damage the input circuitry. However, input voltages outside the input common-mode voltage range will not be able to properly control the output of the amplifier.

**Note 3:** The input voltage applied to either input should not be allowed to go more than  $0.3V$  below the potential applied to pin 4; however, either input can be taken as high as  $15V$  without causing damage to the circuit. Input voltages below the minimum common-mode voltage range may cause a phase reversal in the output.

**Note 4:** This input current will exist only when the voltage at either input lead is driven negative. It is due to the base-isolation junction of the PNP transistor tub becoming forward biased and thereby acting as an input diode clamp. In addition to this diode action, there is also lateral NPN parasitic action on the IC chip. This transistor action can cause the output to take an undefined state for the time duration that an input is driven negative.

**Note 5:**  $V_O = 6V, R_S = 0\Omega$ , and over the full input common-mode voltage range.

**Note 6:** Supply current is measured with the amplifier connected in a unity gain follower configuration and the positive input set to one-half of the supply voltage.

## Typical Performance Characteristics

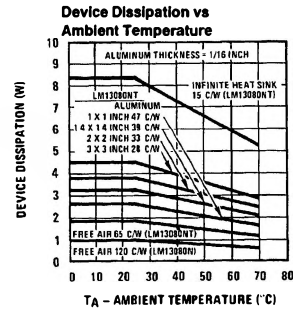
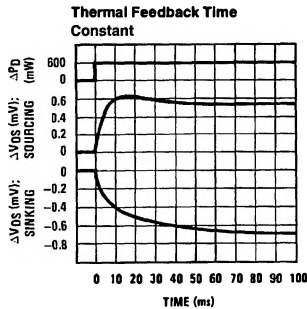
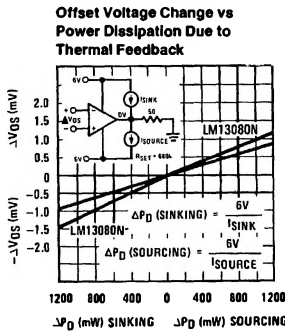
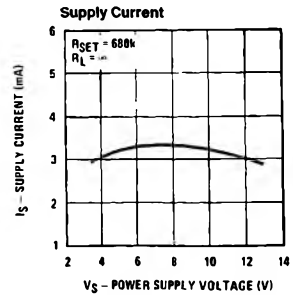
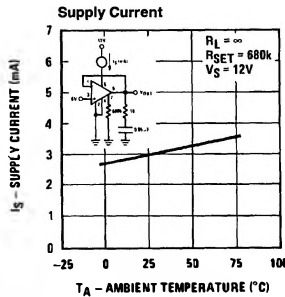
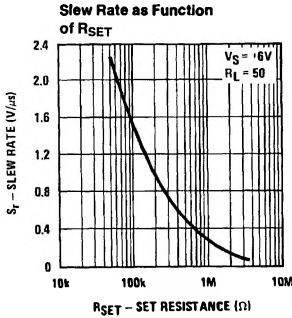

# Typical Performance Characteristics (Continued)

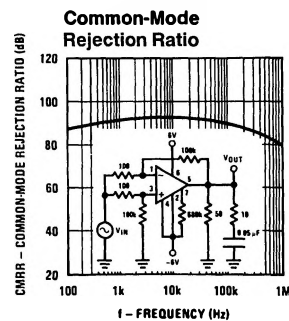
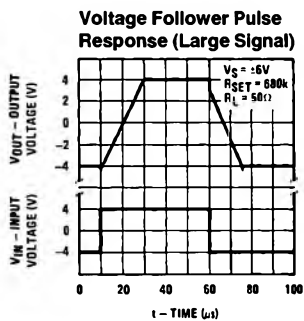
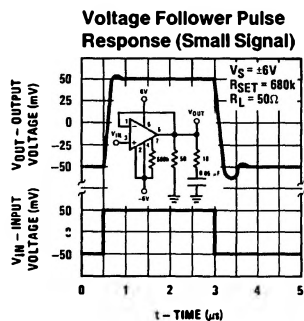
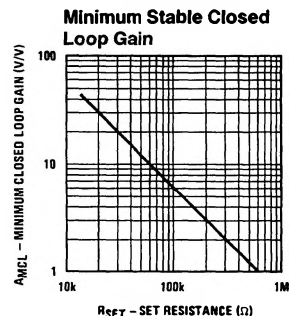
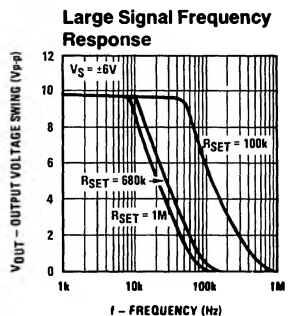
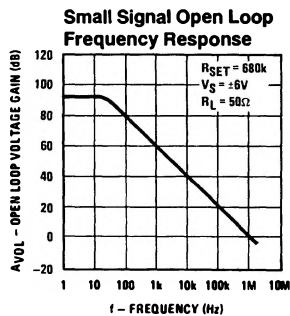
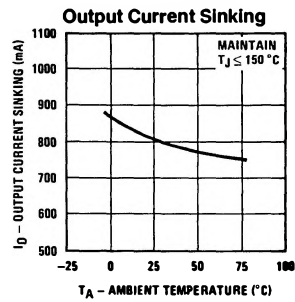
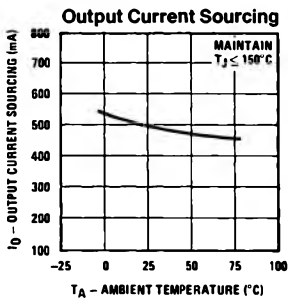
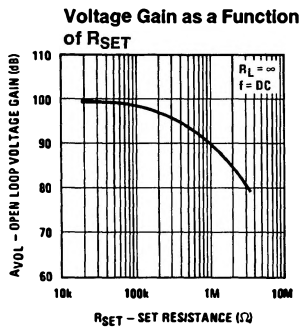
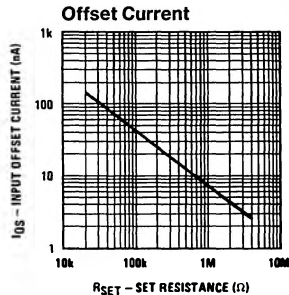
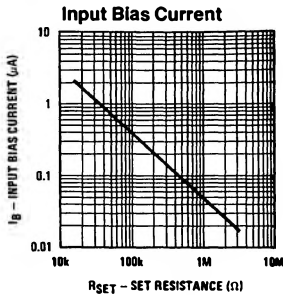
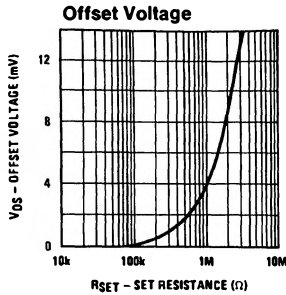

## Application Hints

The LM13080 is a power op amp capable of sourcing or sinking more than 250 mA and does not include internal current limit or thermal shut-down. Therefore, the user must make sure that his application will not cause the power dissipation rating of the package to be exceeded. The LM13080 is rated at a maximum dissipation of 1250 mW at 25°C. For operation at temperatures above 25°C, the maximum dissipation must be derated using the equation:

$$P_D = \frac{T_J - T_A}{\Theta_{JA}}$$

where  $P_D$  is the maximum allowable power dissipation,  $T_J$  is the maximum junction temperature (150°C),  $T_A$  is the ambient temperature and  $\Theta_{JA}$  is the thermal resistance of the package operated in a still air environment.  $\Theta_{JA}$  for the LM13080N is 100°C/W. For example, if the LM13080N is used in free air in a 70°C ambient, the maximum power that can be dissipated is:

$$P_D = \frac{150^\circ\text{C} - 70^\circ\text{C}}{100^\circ\text{C}/\text{W}} = 800 \text{ mW}$$

The LM13080 derives its ability to sink current through the use of a composite NPN/PNP output configuration. This local loop must be compensated by the series connection of a 0.05  $\mu\text{F}$  capacitor and a 10 $\Omega$  resistor between the output of the op amp (pin 5) and the negative power supply (pin 4). The RC does not just filter out the oscillation from the output waveform but actually stabilizes the loop.

If the inputs of the LM13080 are driven below the input common-mode voltage range, it is possible that the output will experience a phase reversal. This is particularly true for the non-inverting input ( $V_{IN(+)}$ ). If either input is driven to a voltage level 0.3V below the substrate (pin 4) a parasitic NPN transistor will be turned ON. The emitter of this parasitic transistor is the normal input transistor epi (N-type, base) region, the base is the substrate (P-type) and the collector is every other epi region on the die. Circuit operation in this mode is unpredictable. If an input is forced below the substrate, the current flowing out of that input should be limited to 20 mA to insure that the amplifier will not be destroyed.

Programming the LM13080 is accomplished by selecting the value of  $R_{SET}$ , the input stage bias resistor, to optimize the amplifier for each particular application. An example would be an application with low source resistance which requires a low offset voltage to make a precise DC measurement. By selecting an  $R_{SET}$  of 100 k $\Omega$ , the normal offset voltage would be reduced to approximately one-fourth the value it would be if a 680k resistor was used. By studying the curves, it can be seen that the bias current will increase but an increase here has very little effect due to the small source impedance. It should also be noted that with a 100k input set resistor the gain bandwidth product will also increase, and in fact, the amplifier must be operated with a closed loop voltage gain of 6 to assure stability.

The effect of  $R_{SET}$  on the total quiescent supply current will be very small ( $\Delta I_S < 5\%$ ) as long as  $R_{SET}$  is 100k or greater.

To employ electronic shut-down the output bias pin, pin 2, and the negative end of the input bias resistor,  $R_{SET}$ , are connected to the negative power supply (or ground in a single power system) through a saturated NPN transistor (or other electronic switch). When the transistor is turned OFF, all of the bias currents inside the op amp are turned OFF and all input and output terminals will float. When first turned ON, the output will take about 5  $\mu\text{s}$  to reach the correct level. To insure that the LM13080 is OFF, leakage in the control device must be below the level that will allow pins 2 and 7 to fall to 0.4V below  $V^+$ .

Power supply rejection is a function of the change in voltage across the input bias resistor,  $R_{SET}$ . To improve the PSRR of the LM13080, the user must be careful to bypass pin 7 to pin 6 or to establish a floating voltage referenced to the positive power supply to serve as a connection point for  $R_{SET}$ . In applications where PSRR is important, it is imperative that a supply bypass capacitor(s) be used.

## Typical Applications

### LINE DRIVER

The line driver circuit in *Figure 1* is able to accept an unbalanced, high impedance input and convert it to a balanced output suitable for driving a low impedance line. This is particularly useful in an environment where magnetically induced hum or noise pickup is a problem.

The outputs of the 2 LM13080s are of opposite polarity; therefore, terminating the line with a balanced load (i.e., a differential amplifier or a transformer) will cause common-mode interference pickup to be cancelled.

This circuit will drive a 20 Vp-p signal into a 50 $\Omega$  load for frequencies up to 10 kHz. Above 10 kHz the output signal is slew rate limited, but the line driver will still supply a 13 Vp-p signal at 20 kHz. The voltage gain of the network is 2, and the low frequency roll-off is determined by:

$$f_L = \frac{1}{2\pi RC}$$

It can be seen that if the load is connected directly between the outputs of the amplifiers, the line driver becomes a simple bridge amplifier capable of delivering 2W into a 16 $\Omega$  load.

### PIEZOELECTRIC ALARM

The piezoelectric alarm shown in *Figure 2* uses a 3-terminal transducer (Gulton 101FB or equivalent) to produce an 80 dB SPL alarm.

The transducer has a feedback terminal which is connected to the non-inverting input of the LM13080, causing oscillation at the resonant frequency of the piezoelectric crystal. The alarm can be controlled through the use of the electronic shut-down feature of the amplifier. The 100k resistor and 0.1  $\mu\text{F}$  capacitor are used to provide a reference voltage at the inverting input and to keep the duty cycle of the crystal oscillation close to 50%. The RC time constant of this feedback network should be much greater than the time constant of the transducer.

Typical Applications (Continued)

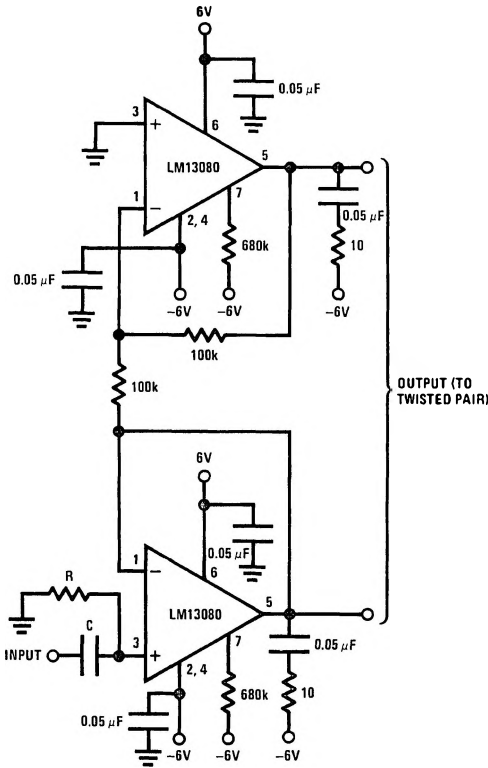

FIGURE 1. Line Driver—Unbalanced Input to Balanced Output

TL/H/7978-5

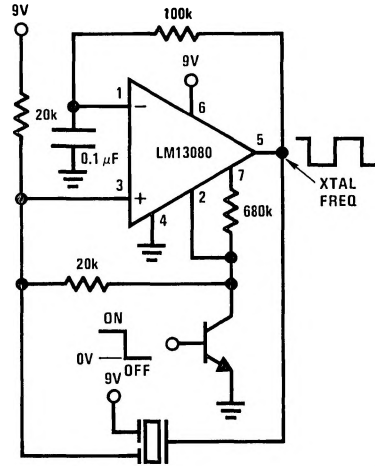

FIGURE 2. Piezoelectric Alarm

TL/H/7978-6

SIRENS

Two separate circuits for sirens are shown. The first, *Figure 3*, is a 2-state or ON-OFF type siren where the LM13080 oscillates at an audio frequency and drives an 8Ω speaker and the LM339 acts as a switch which controls the audio burst rate. The second siren, *Figure 4*, provides a constant audio output but alternates between 2 separate tones. The LM13080 is set to oscillate at one basic frequency and this frequency is changed by adding a 200 kΩ charging resistor in parallel with the feedback resistor, R2.

LAMP FLASHER—RELAY DRIVER

The LM13080 is easily adaptable to such applications as low frequency warning devices. The output of the oscillator is a squarewave that is used to drive lamps or small relays. As shown in *Figure 5*, the circuit alternately flashes 2 incandescent lamps.

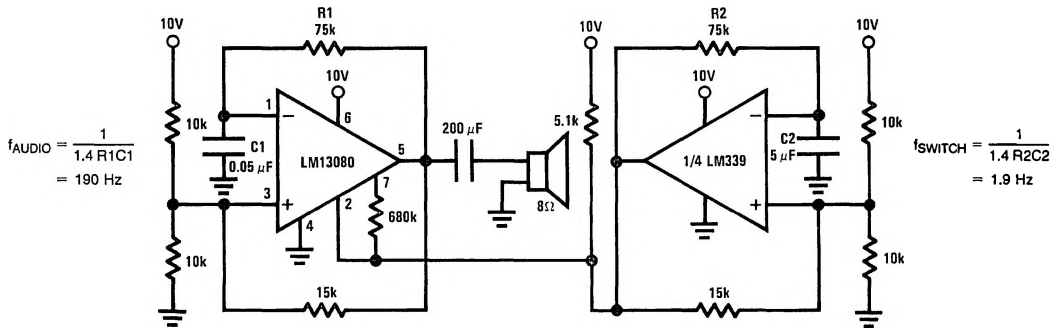

$$f_{\text{AUDIO}} = \frac{1}{1.4 R1 C1} = 190 \text{ Hz}$$

$$f_{\text{SWITCH}} = \frac{1}{1.4 R2 C2} = 1.9 \text{ Hz}$$

FIGURE 3. 2-State Siren

TL/H/7978-7

## Typical Applications (Continued)

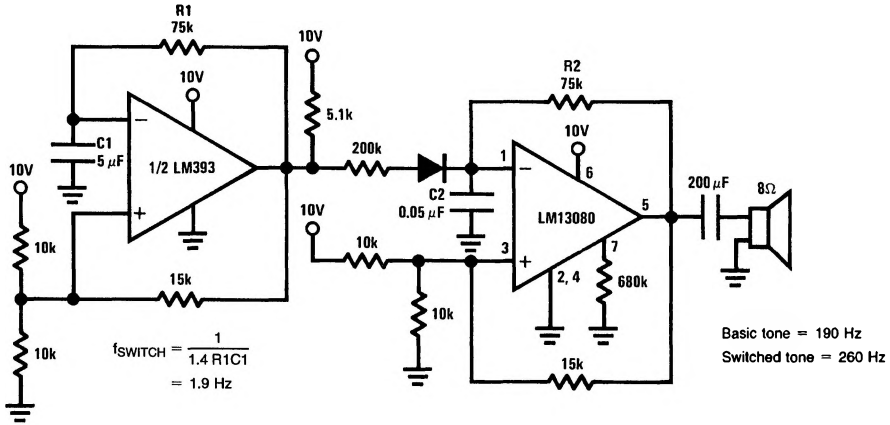

FIGURE 4. 2-Tone Siren

TL/H/7978-8

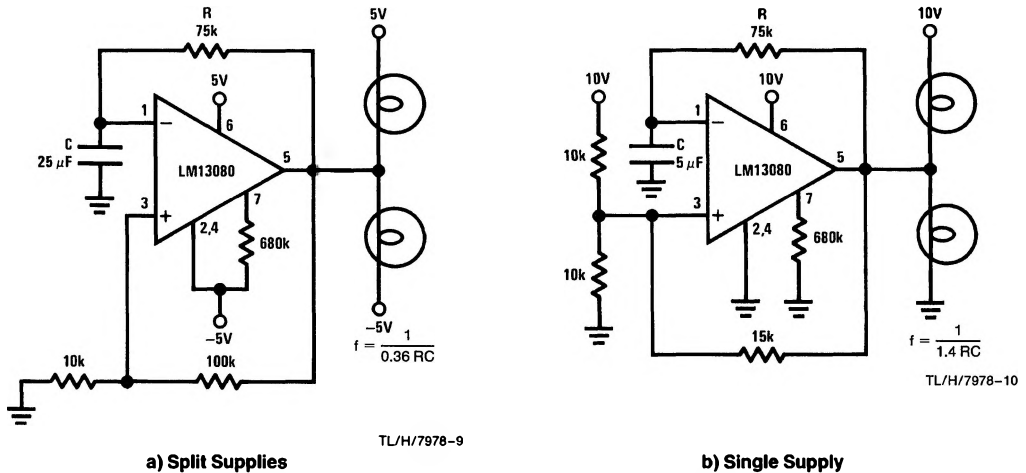

FIGURE 5. Low Frequency Lamp Flasher/Relay Driver

### MOTOR SPEED CONTROL

The LM13080 can be used to construct a very simple speed control for small motors requiring less than 0.5A start current. This circuit operates by impressing the multiple of a reference voltage across the motor, and then varying the reference by means of a quasi-positive feedback to change the voltage across the motor any time the load on the motor changes.

To understand the circuit operation, it is easiest to let the voltage at the cathode of diode D1, *Figure 6*, be the input

voltage,  $V_{IN}$ , to the system. Diode D1 is actually a level shift diode to bring  $V_{IN}$  into the common-mode range of the amplifier. A reference voltage is established by the combined voltage drop through the  $10\Omega$  potentiometer, R3 and the reference diode, D2 and is applied to the non-inverting input of the LM13080. Resistor R4 is a bias resistor used to keep D2 active. The  $10k$  speed adjust potentiometer is 2 resistors in 1, where section R1 is the input resistance and section R2 is the negative feedback resistance. It can be seen that the voltage impressed across the motor is equal to:

$$V_{\text{MOTOR}} = \frac{(V_{BE2} + I_3 R_3) R_2}{R_1} + V_{BE}$$

**Typical Applications** (Continued)

The positive feedback is developed as a change in the voltage across R3 due to the change in the motor current caused by a variation in the motor's load. Resistor R3 is shown as a potentiometer so that the amount of positive feedback can be adjusted for smooth operation of the motor. Capacitor C1 and resistor R5 serve as a filter for the reference voltage at the non-inverting input of the amplifier.

**VOLTAGE REGULATORS**

In normal, positive or negative regulator application such as those shown in *Figure 7* and *Figure 8*, the LM13080 has 2 major advantages over standard operational amplifiers. The LM13080 has its own on-chip pass device and in addition can either sink or source 250 mA of load current.

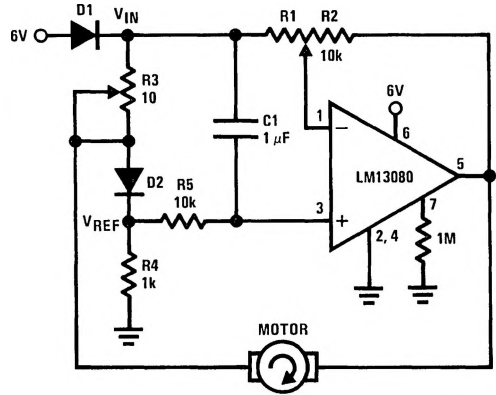

TL/H/7978-11

**FIGURE 6. Motor Speed Control**

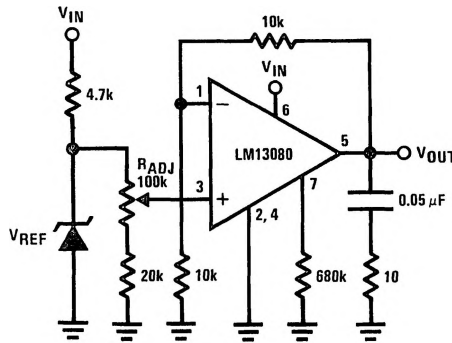

$2V \leq V_{OUT} \leq (V_{IN} - 2V)$

TL/H/7978-12

**FIGURE 7. Positive Variable Voltage Regulator**

**Note:** Pin numbers apply to miniDIP.

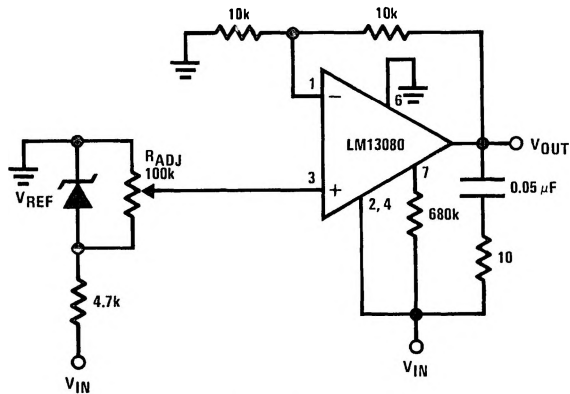

$-15V \geq V_{OUT} \geq -(V_{IN} - 2V)$

TL/H/7978-13

**FIGURE 8. Negative Variable Voltage Regulator**