



SIM8200EA-M2

Hardware Design

5G Module

SIMCom Wireless Solutions Limited.

Building B, SIM Technology Building, No.633, Jinzhong Road

Changning District, Shanghai P.R.China

Tel: 86-21-31575100

support@SIMcom.com

www.SIMcom.com

Document Title:	SIM8200EA-M2 Hardware Design
Version:	V1.03
Date:	2020-06-05
Status:	Released

GENERAL NOTES

SIMCOM OFFERS THIS INFORMATION AS A SERVICE TO ITS CUSTOMERS TO SUPPORT THE APPLICATION AND ENGINEERING EFFORTS THAT USE THE PRODUCTS DESIGNED BY SIMCOM. THE INFORMATION PROVIDED IS BASED ON THE REQUIREMENTS SPECIFICALLY FROM THE CUSTOMERS. SIMCOM HAS NOT UNDERTAKEN ANY INDEPENDENT SEARCH FOR ADDITIONAL RELEVANT INFORMATION, INCLUDING ANY INFORMATION THAT MAY BE IN THE CUSTOMER'S POSSESSION. FURTHERMORE, THE SYSTEM VALIDATION OF THE PRODUCT DESIGNED BY SIMCOM WITHIN A LARGER ELECTRONIC SYSTEM REMAINS THE RESPONSIBILITY OF THE CUSTOMER OR THE CUSTOMER'S SYSTEM INTEGRATOR. ALL SPECIFICATIONS SUPPLIED HEREIN ARE SUBJECT TO CHANGE WITHOUT NOTICE.

COPYRIGHT

THIS DOCUMENT CONTAINS THE PROPRIETARY TECHNICAL INFORMATION WHICH IS THE PROPERTY OF SIMCOM LIMITED, COPYING OF THIS DOCUMENT, GIVING IT TO OTHERS, THE USING OR COMMUNICATION OF THE CONTENTS THEREOF ARE FORBIDDEN WITHOUT THE OFFICIAL AUTHORITY BY SIMCOM. OFFENDERS ARE LIABLE TO THE PAYMENT OF THE DAMAGES. ALL RIGHTS ARE RESERVED IN THE EVENT OF GRANT OF A PATENT OR THE REGISTRATION OF A UTILITY MODEL OR DESIGN. ALL SPECIFICATIONS SUPPLIED HEREIN ARE SUBJECT TO CHANGE WITHOUT NOTICE.

SIMCom Wireless Solutions Limited

Building B, SIM Technology Building, No.633 Jinzhong Road, Changning District, Shanghai P.R.China

Tel: +86 21 31575100

Email: SIMcom@SIMcom.com

For more information, please visit:

<https://www.SIMcom.com/download/list-863-en.html>

For technical support, or to report documentation errors, please visit:

<https://www.SIMcom.com/ask/> or email to: support@SIMcom.com

Copyright © 2020 SIMCom Wireless Solutions Limited All Rights Reserved.

Version History

Data	Version	Description of change	Author
2019-06-27	1.00	original version	Olivier.wu Xutao.jiang Cunbao.feng
2019-09-25	1.01	Modify the error	Olivier.wu
2019-12-19	1.02	Antenna interfaces update Modify table 3	Yibo.zhong
2020-06-05	1.03	Modify the error Modify the format	Yao.chen

SIMCom
Confidential

Contents

Contents	4
Table Index	6
Figure Index	8
1. Introduction	9
1.1 Product Outline	9
1.2 Hardware Block Diagram	10
1.3 Feature Overview	11
2. Package Information	13
2.1 Pin Assignment Overview	13
2.2 Pin Description.....	14
2.3 Mechanical Dimensions.....	18
3. Interface Application	19
3.1 Power Supply.....	19
3.1.1 Power Supply Design Guide.....	19
3.1.2 Recommended Power Supply Circuit	21
3.1.3 Voltage Monitor.....	22
3.2 Power On and Off Module	22
3.2.1 Power On.....	23
3.2.2 Power Off.....	24
3.3 Reset Function.....	25
3.4 I2C Interface	27
3.5 WoWWAN#*	28
3.6 USB Interface	29
3.7 PCIe Interface.....	31
3.8 (U)SIM Interface	33
3.9 I2S Interface	35
3.9.1 I2S Timing.....	36
3.9.2 I2S Reference Circuit	37
3.10 DPR*	39
3.11 CONFIG Pins	40
3.12 LED1#*	40
3.13 W_DISABLE1#	41
3.14 W_DISABLE2#*	43
3.15 Antenna Control Interface*	44
4. Antenna Interfaces	45
4.1 Antenna Definitions.....	45
4.1.1 3G/4G/5G Operating Frequency.....	47

4.1.2 GNSS Frequency	48
4.2 Antenna Installation	48
4.2.1 Antenna Requirements	48
4.2.2 RF Plug Recommendation.....	50
5. Electrical Specifications	52
5.1 Absolute Maximum Ratings	52
5.2 Operating Conditions	52
5.3 Operating Mode	53
5.3.1 Operating Mode Definition	53
5.3.2 Sleep Mode	54
5.3.3 Minimum Functionality Mode and Flight Mode	54
5.4 Current Consumption.....	55
5.5 RF Output Power	57
5.6 Conducted Receive Sensitivity	58
5.7 Thermal Design	60
5.8 ESD	61
6. Appearance	62
6.1 Top and Bottom View of SIM8200EA-M2.....	62
6.2 Label Description Information	62
7. Packaging	64
8. Appendix	66
8.1 Coding Schemes and Maximum Net Data Rates over Air Interface	66
8.2 Related Documents	68
8.3 Terms and Abbreviations.....	69
8.4 Safety Caution.....	71

Table Index

Table 1: SIM8200EA-M2 frequency bands.....	9
Table 2: Key features	11
Table 3: IO parameters definition	14
Table 4: DC parameters definition.....	14
Table 5: Pin description.....	15
Table 6: VBAT pins electrical characteristics.....	19
Table 7: Definition of VBAT and GND pins	20
Table 8: Recommended D1 and D2 list	21
Table 9: Definition of FULL_CARD_POWER_OFF# pin.....	23
Table 10: Power on timing and electrical characteristics.....	24
Table 11: Power off timing and electrical characteristics	25
Table 12: Definition of RESET# pin	25
Table 13: RESET# pin electrical characteristics.....	26
Table 14: Definition of I2C interface.....	27
Table 15: Definition of WoWWAN# pin	28
Table 16: Definition of USB interface	30
Table 17: USB interface recommended TVS diode list	30
Table 18: Definition of PCIe interface.....	32
Table 19: PCIe interface recommended TVS diode list.....	32
Table 20: (U)SIM electrical characteristics in 1.8V mode ((U)SIM_PWR=1.8V)	33
Table 21: (U)SIM electrical characteristics in 3.0V mode ((U)SIM_PWR=3.0V)	33
Table 22: Definition of (U)SIM interface	34
Table 23: Recommended TVS and (U)SIM socket list	35
Table 24: I2S format.....	35
Table 25: I2S timing parameters	36
Table 26: Definition of I2S interface	37
Table 27: The PCM interface is multiplexing with I2S interface.....	37
Table 28: Definition of WoWWAN# pin.....	39
Table 29: CONFIG pins state of the module	40
Table 30: CONFIG interface definition	40
Table 31: Definition of LED1# pin	41
Table 32: LED1# pin status	41
Table 33: Definition of W_DISABLE1# pin.....	42
Table 34: W_DISABLE1# pin status	42
Table 35: Definition of W_DISABLE2# pin.....	43
Table 36: W_DISABLE2# pin status	43
Table 37: Definition of antenna control interface through GPIOs.....	44
Table 38: Antenna port definitions.....	45
Table 39: SIM8200EA-M2 frequency band and antenna ports mapping.....	46
Table 40: The module operating frequency.....	47

Table 41: GNSS frequency	48
Table 42: 3G/4G/5G/GNSS antennas	49
Table 43: GNSS antenna (for dedicated GNSS antenna only)*	49
Table 44: Electrical Specifications of MM4829-2702B/RA4/RB0	50
Table 45: Absolute maximum ratings	52
Table 46: VBAT recommended operating ratings	52
Table 47: 1.8V Digital I/O characteristics	52
Table 48: Operating temperature	53
Table 49: Operating mode definition	53
Table 50: Current consumption on VBAT pins (VBAT=3.8V)	55
Table 51: Conducted output power	57
Table 52: Conducted RF receiving sensitivity	58
Table 53: The ESD performance measurement table (Temperature: 25°C, Humidity: 45%)	61
Table 54: Label description of the module information	63
Table 55: Tray size	64
Table 56: Small carton size	65
Table 57: Big carton size	65
Table 58: Coding schemes and maximum net data rates over air interface	66
Table 59: Related documents	68
Table 60: Terms and abbreviations	69
Table 61: Safety caution	71

SIMCom
Confidential

Figure Index

Figure 1: Block diagram	10
Figure 2: Pin assignment	13
Figure 3: Dimensions of the module (unit: mm)	18
Figure 4: VBAT voltage drop at the maximum power radio transmission	19
Figure 5: Power supply application circuit.....	20
Figure 6: Linear regulator reference circuit	21
Figure 7: Switching mode power supply reference circuit.....	22
Figure 8: Reference power on/off circuit	23
Figure 9: Power on sequence	23
Figure 10: Power off sequence	24
Figure 11: Reference reset circuit	25
Figure 12: The reset timing sequence of the module	26
Figure 13: I2C reference circuit.....	27
Figure 14: WoWWAN# signal level at SMS and URC report	28
Figure 15: WoWWAN# reference circuit	28
Figure 16: USB reference circuit.....	29
Figure 17: PCIe interface reference circuit (EP Mode).....	31
Figure 18: (U)SIM interface reference circuit	34
Figure 19: I2S timing.....	36
Figure 20: Audio codec reference circuit.....	37
Figure 21: LED1# reference circuit	40
Figure 22: W_DISABLE1# pin reference circuit	42
Figure 23: W_DISABLE2# pin reference circuit	43
Figure 24: Antenna interfaces	45
Figure 25: 3D view of MM4829-2702B/ RA4/ RBO	50
Figure 26: 3D view of MXHJD3HJ1000	51
Figure 27: Thermal dissipation area on bottom side of the module	60
Figure 28: Top and bottom view of the module	62
Figure 29: Label description of the module	63
Figure 30: Packaging procedures	64
Figure 31: Tray view of the module	64
Figure 32: Small carton view.....	65
Figure 33: Big carton view	65

1. Introduction

This document describes the electronic specifications, RF specifications, interfaces, mechanical characteristics and test results of the SIM8200EA-M2 module. With the help of this document, customers can quickly understand SIM8200EA-M2 module.

Associated with other software application notes and user guides, customers can use SIM8200EA-M2 to design and develop mobile and laptop applications easily.

1.1 Product Outline

SIM8200EA-M2 is a wireless communication module focusing on 5G market; it supports multi-air access technology including 5G NR (NSA/SA), LTE-FDD, LTE-TDD, and WCDMA, can meet the 3GPP R15 NR specification, and also integrates GNSS system including dual bands GPS, GLONASS, Beidou, Galileo and QZSS.

The module's supported radio frequency bands are shown in the following table.

Table 1: SIM8200EA-M2 frequency bands

Standard	Frequency Bands
5G NR	n1/n2/n3/n5/n7/n8/n12/n20/n25/n28/n40/n41/n66/n71/n77/n78/n79 ¹
LTE-FDD	B1/B2/B3/B4/B5/B7/B8/B12/B13/B14/B17/B18/B19/B20/B25/B26/B28/B29/B30/B32/B66/B71
LTE-TDD	B34/B38/B39/B40/B41/B42/B48
WCDMA	B1/B2/B3/B4/B5/B8
GNSS ²	GPS L1+L5 dual bands/GLONASS/BeiDou/Galileo/QZSS

NOTE

1. Default design can support 5G n77/n78, n79 support need another hardware variant.
2. GNSS is optional.

With a physical dimension of 30.0mm*52.0mm*2.3mm, SIM8200EA-M2 can meet PCI Express M.2 specifications, and can meet almost any space requirement in users' applications.

With M.2 Type 3052, SIM8200EA-M2 owns rich interfaces, includes USB3.1, PCIe3.0, (U)SIM card, digital audio(I2S or PCM), I2C, GPIOs, six antennas for 3G/4G/5G and GNSS.

With all the interfaces, SIM8200EA-M2 can also be utilized in the handheld terminal, machine-to-machine laptop application and especially the router.

1.2 Hardware Block Diagram

The block diagram of SIM8200EA-M2 is shown in the following figure.

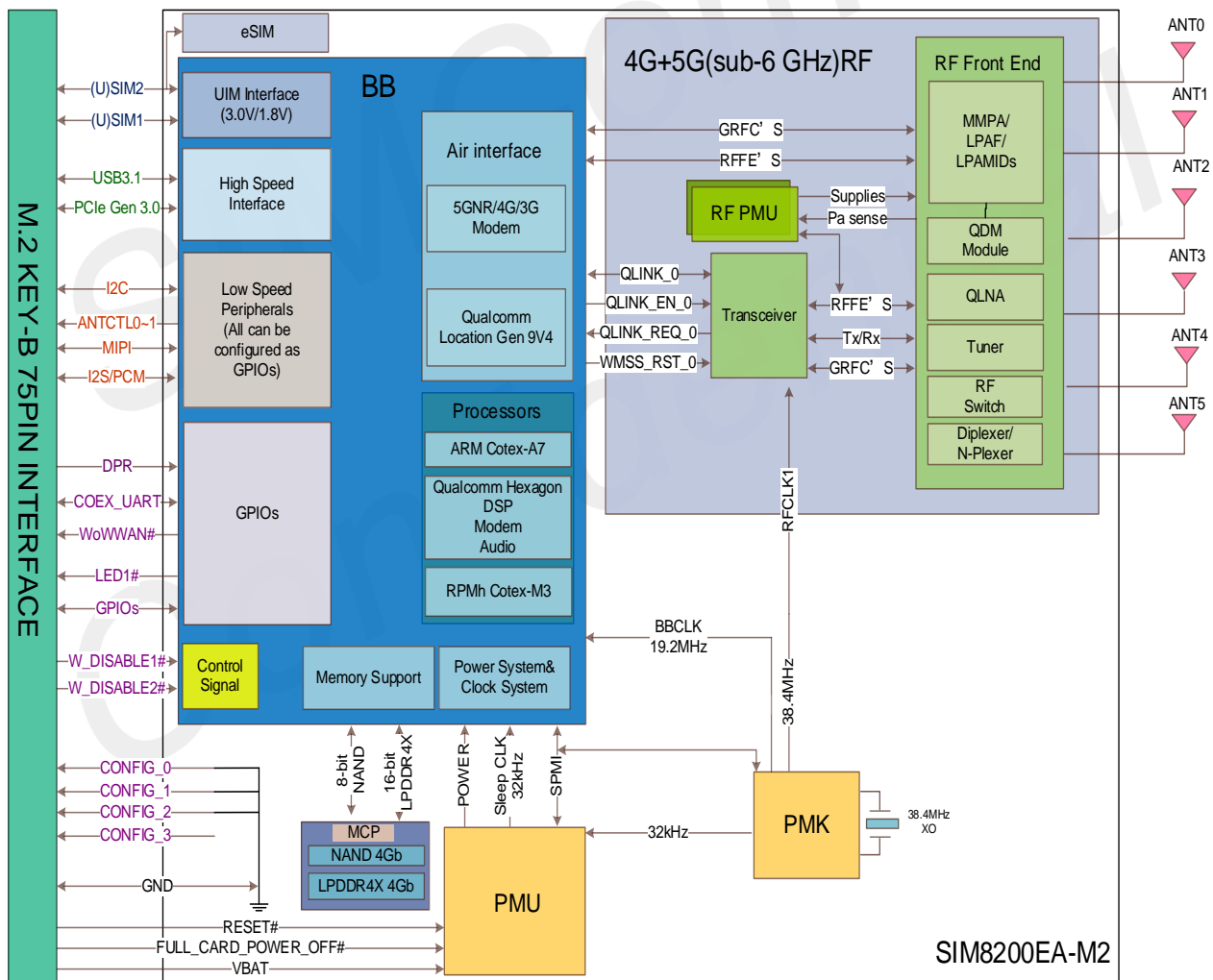

Figure 1: Block diagram

1.3 Feature Overview

Table 2: Key features

Feature	Implementation
Power supply	VBAT: 3.135~4.4V Typical: 3.8V
Power consumption	<5mA @sleep mode*
Transmit power	Power Class 3 for WCDMA/LTE/5G NR Power Class 2 for n41/n78/n79
Data transmission throughput	4Gbps (DL)/500Mbps(UL) for NR 2Gbps (DL)/200Mbps (UL) for LTE 42Mbps(DL)/5.76Mbps(UL) for HSPA+
Antenna	Six antennas for 3G/4G/5G and GNSS
GNSS	GNSS engine : GPS L1+L5/GLONASS/BeiDou/Galileo/QZSS Protocol: NMEA
SMS	MT, MO, CB, Text and PDU mode SMS storage: (U)SIM card or ME(default) Transmission of SMS alternatively over CS or PS
(U)SIM interface	Support (U)SIM card:1.8V/3.0V Include USIM1 and USIM2 interfaces Support dual SIM single standby
(U)SIM application toolkit	Support SAT class 3 Support USAT
Phonebook management	Support phonebook types: DC,MC,RC,SM,ME,FD,ON,LD,EN
Digital audio interface	One I2S interface with dedicated main-clock for primary digital audio, the I2S also can be configured as PCM <ul style="list-style-type: none"> ● MCLK frequency: 12.288MHz (default) ● WCDMA AMR-NB ● VoLTE AMR-WB ● Echo Cancellation ● Noise Suppression
PCIe interface	<ul style="list-style-type: none"> ● One lane PCIe interface, support Gen 3 (Gen 1/2 compatible) ● High communication data rate which up to 8Gbps
I2C interface	<ul style="list-style-type: none"> ● Meet I2C specification, version 5.0 ● Data rate up to 400Kbps
USB	Support USB 3.1 Gen2 or USB 2.0 USB3.1: super speed, with data rate which up to 10Gbps USB2.0: high speed interface, support USB operations at low-speed and full-speed, which refer to USB1.0 and USB1.1
Firmware upgrade	Firmware upgrade over USB interface
Physical characteristics	Size: 30mm*52mm*2.3mm

	Weight: 8.30g
Temperature range	Normal operation temperature: -30°C to +70°C 3GPP compliant Extended operation temperature: -40°C to +85°C ² Storage temperature: -40°C to +90°C

NOTE

1. “*” means under development.
2. The module is able to establish and maintain voice, data transmission, SMS and emergency call, etc. The performance may deviate slightly from the 3GPP specifications and will meet 3GPP specifications again when the temperature returns to normal operating temperature levels.

SIMCom
Confidential

2.2 Pin Description

Table 3: IO parameters definition

Pin Type	Description
PI	Power Input
PO	Power Output
AI	Analog Input
AIO	Analog Input/Output
DIO	Bidirectional Digital Input /Output
DI	Digital Input
DO	Digital Output
DOH	Digital Output with High level
DOL	Digital Output with Low level
PU	Pull Up
PD	Pull Down
OD	Open Drain
OC	Open Collector

Table 4: DC parameters definition

Voltage Domain	Parameter		Min	Typ	Max
P3	VDD_P3=1.8V				
	V _{OH}	High level output	1.35V	-	1.8V
	V _{OL}	Low level output	0V	-	0.45V
	V _{IH}	High level input	1.26V	1.8V	2.1V
	V _{IL}	Low level input	0V	-	0.54V
	R _p	Pull up/down resistor	20K ohm	-	60K ohm
P4/P5	VDD_P4/P5=1.8V				
	V _{OH}	High level output	1.44V	-	1.8V
	V _{OL}	Low level output	0V	-	0.4V
	V _{IH}	High level input	1.26V	-	1.95V
	V _{IL}	Low level input	0V	-	0.36V
	R _p	Pull up/down resistor	10K ohm	-	100K ohm
	VDD_P4/P5=3.0V				
	V _{OH}	High level output	2.4V	-	3.0V
	V _{OL}	Low level output	0V	-	0.4V
	V _{IH}	High level input	2.1V	-	3.05V
	V _{IL}	Low level input	0V	-	0.6V
	R _p	Pull up/down	10K ohm		100K ohm

Table 5: Pin description

Pin Name	Pin No.	Electrical Description	Description	Comment
Power Supply				
VBAT	2,4,70,7 2,74		PI Power supply Range : 3.135~4.4V Typical : 3.8V	These pins should be connected together to withstand sufficient current
GND	3,5,11,2 7,33,39, 45,51,5 7,71,73		Ground	
System Control				
FULL_CARD_POWER_OFF#	6		DI,PD High level: the module power on Low level: the module power off	It's 3.3V tolerant but can be driven by either 1.8V or 3.3V GPIO
RESET#	67	P3	DI,PU System reset control input Active low	RESET# has been pulled up to 1.8V internally
W_DISABLE1#	8		DI WWAN RF disable Active low	3.3V tolerant but can be driven by either 1.8V or 3.3V GPIO
W_DISABLE2#*	26		DI GNSS disable Active low	3.3V tolerant but can be driven by either 1.8V or 3.3V GPIO
WoWWAN#	23		OD Wake on the host Active low	
Configuration Pins				
CONFIG_0	21		GND Connected to ground internally	The module is configured as the WWAN USB3.1 interface type
CONFIG_1	69		GND Connected to ground internally	
CONFIG_2	75		GND Connected to ground internally	
CONFIG_3	1		NC Not connected	
USB2.0/USB3.1				
USB_D+	7		AIO Differential USB bi-directional data positive	Main communication interface USB3.1 data rate up to 10Gbps USB2.0 data rate up to 480Mbps
USB_D-	9		AIO Differential USB bi-directional data negative	
USB3.1_Tx-	29		AO USB3.1 transmit data negative	
USB3.1_Tx+	31		AO USB3.1 transmit data positive	
USB3.1_Rx-	35		AI USB3.1 receive data negative	
USB3.1_Rx+	37		AI USB3.1 receive data positive	
PCIe Interface				
PETn0	41		AO PCIe transmit data	Support PCIe Gen 3.0,

				negative	data rate up to 8Gbps. If unused, please keep open
PETp0	43		AO	PCIe transmit data positive	
PERn0	47		AI	PCIe receive data negative	
PERp0	49		AI	PCIe receive data positive	
REFCLKN	53		AIO	PCIe reference clock negative	
REFCLKP	55		AIO	PCIe reference clock positive	
PCIe Assistant Interface					
PERSTR#	50		DI	PCIe reset signal Active low	3.3V voltage domain, CLKREQ# and PEWAKE# required pull up external, Default as EP mode, If unused, please keep open
CLKREQ#	52		DIO	PCIe reference clock request signal Active low	
PEWAKE#	54		DIO	PCIe wake up control Active low	
(U)SIM Interface					
(U)SIM1_PWR	36		PO	Power supply for (U)SIM1 card	1.8/3.0V voltage domain, (U)SIM interfaces should be protected against ESD , If unused, please keep open
(U)SIM1_DATA	34	P4	DIO	(U)SIM1 card data, which has been pulled up to (U)SIM1_VDD via a 20KR resistor internally	
(U)SIM1_CLK	32	P4	DO	(U)SIM1 clock signal	
(U)SIM1_RESET	30	P4	DO	(U)SIM1 reset control	
(U)SIM1_DET	66	P3	DI	(U)SIM1 card detect, which has been pulled up to VDD_P3 via a 470KR resistor internally	
(U)SIM2_PWR	48		PO	Power supply for (U)SIM2 card	
(U)SIM2_DATA	42	P5	DIO	(U)SIM2 card data, which has been pulled up to (U)SIM2_VDD via a 20KR resistor internally	
(U)SIM2_CLK	44	P5	DO	(U)SIM2 clock signal	
(U)SIM2_RESET	46	P5	DO	(U)SIM2 reset control	
(U)SIM2_DET	40	P3	DI	(U)SIM2 card detect, which has been pulled up to VDD_P3 via a 470KR resistor internally	
Antenna Control Interface²					
ANTCTL0	59	P3	DO	Antenna tuner control0	1.8V voltage domain. If unused, please keep open
ANTCTL1	61	P3	DO	Antenna tuner control1	
ANTCTL 2 (RFFE_SDATA) ³	58	P3	DO (DIO)	Antenna tuner control2 (Antenna tuner MIPI DATA) ³	
ANTCTL3 (RFFE_SCLK) ³	56	P3	DO	Antenna tuner control3 (Antenna tuner MIPI CLK) ³	
I2S Interface					
I2S_CLK	20	P3	DO	I2S clock output	1.8V voltage domain,

I2S_RX	22	P3	DI	I2S data input	also can be used as PCM interface, If unused, please keep open
I2S_TX	24	P3	DO	I2S data output	
I2S_WA	28	P3	DO	I2S word alignment select (L/R)	
I2S_MCLK	60	P3	DO	I2S master clock	
I2C Interface					
I2C_SDA	68	P3	DIO	I2C data signal	1.8V voltage domain, Internal pulled up to 1.8V. If unused, please keep open
I2C_SCL	38	P3	DO	I2C clock signal	
Coex Interface²					
COEX1 (COEX_RX*)	64	P3	DI	Wireless coexistence of WWAN and WiFi/BT, based on BT-sig coexistence protocol	If unused, please keep open
COEX2 (COEX_TX*)	62	P3	DO	Wireless coexistence of WWAN and WiFi/BT, based on BT-sig coexistence protocol	
WL_TX_EN	65	P3	DI	WiFi 5G TX indicator	If unused, please keep open
LAA_TX_EN	63	P3	DO	n79 TX indicator	If unused, please keep open
Other Pins					
LED1#*	10	P3	OD	The module status indicator via LED devices Active low	
DPR*	25	P3	DI	Dynamic power reduction H: Max transmitting power will not be reduced (default) L: Max transmitting power will be reduced	
Notch					
Notch	12, 13, 14, 15, 16, 17, 18, 19			Notch	

NOTE

1. "*" means under development.
2. Please confirm with SIMCom for the detail design about antenna control and coex interface.
3. The RFFE signals are multiplexed with ANTCTL2 and ANTCTL3.

3. Interface Application

3.1 Power Supply

The recommended power supply of SIM8200EA-M2 is 3.8V and the voltage ranges from 3.135 V to 4.4 V. Please make sure that the input voltage will never drop below 3.135V, otherwise the module will be powered off automatically. The module has 5 power pins and 11 ground pins. To ensure the module works properly, all pins should be connected.

Table 6: VBAT pins electrical characteristics

Symbol	Description	Min.	Typ.	Max.	Unit
VBAT	Module power supply voltage	3.135	3.8	4.4	V
I_{peak}	Peak current	-	-	2.7	A
I_{sleep}	Current in sleep mode	-	TBD	-	mA
$I_{leakage}$	Current in power off mode	-	80	-	uA

3.1.1 Power Supply Design Guide

When the module transmits at the maximum power, the peak current can reach 2.7A, which results in voltage dropping on VBAT. To ensure that the voltage is no less than required 3.135V, the capacity of external power supply cannot be less than 3A. The following figure shows the maximum voltage drop during the maximum power radio transmission.

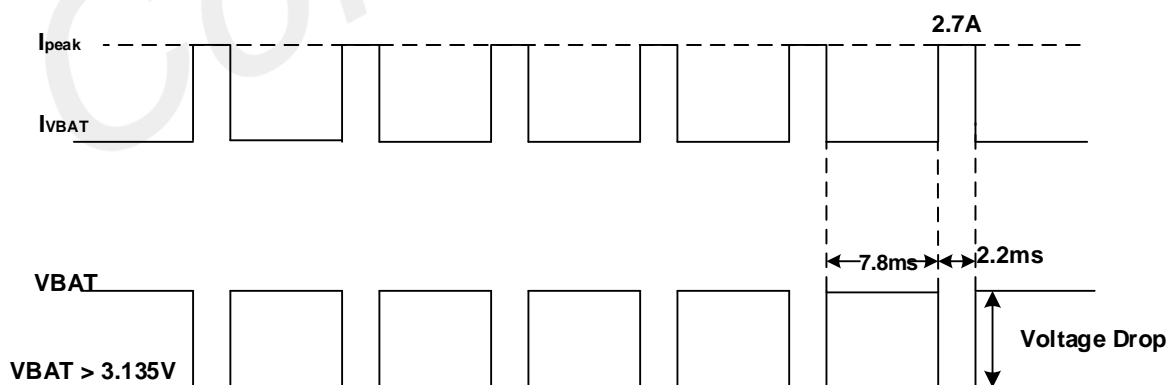

Figure 4: VBAT voltage drop at the maximum power radio transmission

To decrease the voltage dropping, make sure the VBAT voltage no less than 3.135V. The following figure shows the reference circuit of power supply for the VBAT.

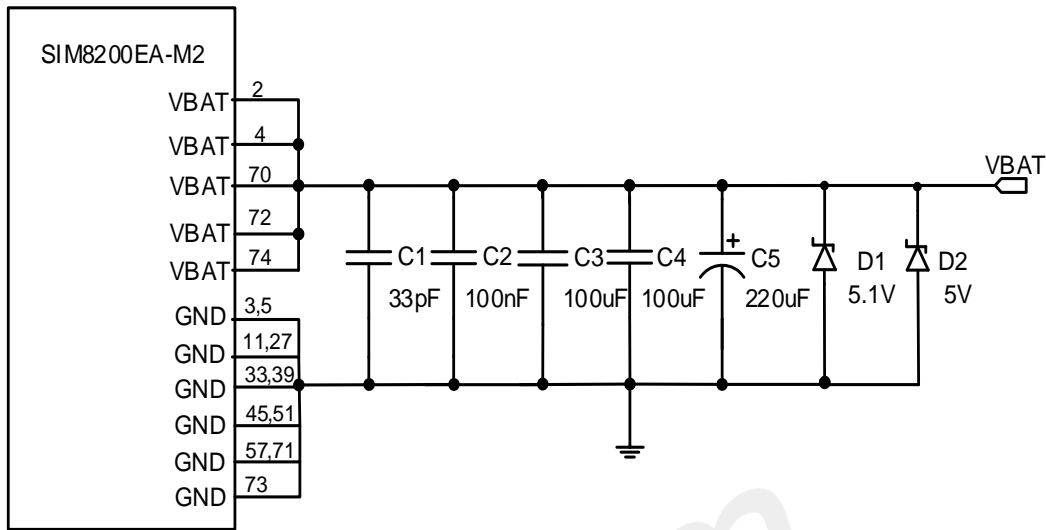

Figure 5: Power supply application circuit

Table 7: Definition of VBAT and GND pins

Pin Name	Pin No.	Electrical Description	Description	Comment
VABT	2,4,70,72,74	PI	Power supply Range : 3.135~4.4V Typical : 3.8V	These pins should be connected together to withstand sufficient current
GND	3,5,11,27,33,39,45,51,57,71,73		Ground	

In this reference circuit, some multi-layer ceramic chip (MLCC) capacitors (0.1/1uF) with low ESR in high frequency band can be used for EMI suppression.

These capacitors should be put as close as possible to VBAT pins. Also, users should keep VBAT trace on circuit board wider than 3.0 mm to minimize PCB trace impedance.

NOTE

1. C5 is 220 μ F tantalum capacitor, ESR=0.7 Ω .
2. C1 and C2 are multi-layer ceramic chip (MLCC) capacitors from 0.1uF to 1uF with low ESR in high frequency band, which can be used for EMC performance.
3. D2 is used for ESD protection and D1 is used for surge protection.

Table 8: Recommended D1 and D2 list

No.	Manufacturer	Part Number	VRWM	Package	Ref. Designator
1	JCET	ESDBW5V0A1	5V	DFN1006-2L	D2
2	WAYON	WS05DPF-B	5V	DFN1006-2L	
3	LRC	LEDZ5.1BT1G	5.1V	SOD-523	D1
4	Prisemi	PZ5D4V2H	5.1V	SOD-523	

Power supply layout guidelines:

- Both VBAT and return trace should be as short and wide as possible to minimize the voltage drop.
- The width of VBAT trace cannot be less than 3.0mm.
- These capacitors should be placed as closely as possible with VBAT pins.
- The VBAT trace should pass through TVS diode, zener diode and capacitors, and then VBAT pins. The capacitor of the small value should be placed close to VBAT pins.
- The PCB design must have a solid ground plane as the primary reference plane for most signals.

3.1.2 Recommended Power Supply Circuit

It is recommended to use a switching mode power supply or a linear regulator power supply. Make sure it can provide the current up to 3A at least.

Figure6 shows the linear regulator reference circuit with 5V input and 3.8V output.

Figure7 shows the switching mode power supply reference circuit with 5~12V input and 3.8V output.

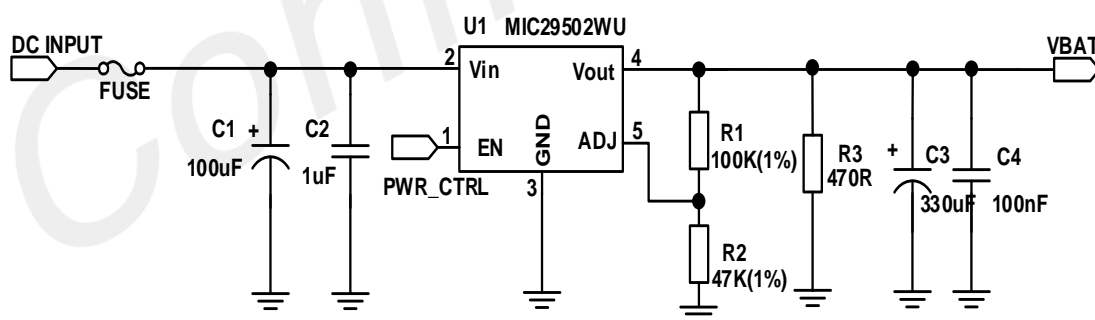

Figure 6: Linear regulator reference circuit

NOTE

An extra minimum load of R3 is required, to ensure it work properly under light load in sleep mode and power off mode. For the details about minimum load, please refer to specification of MIC29502WU.

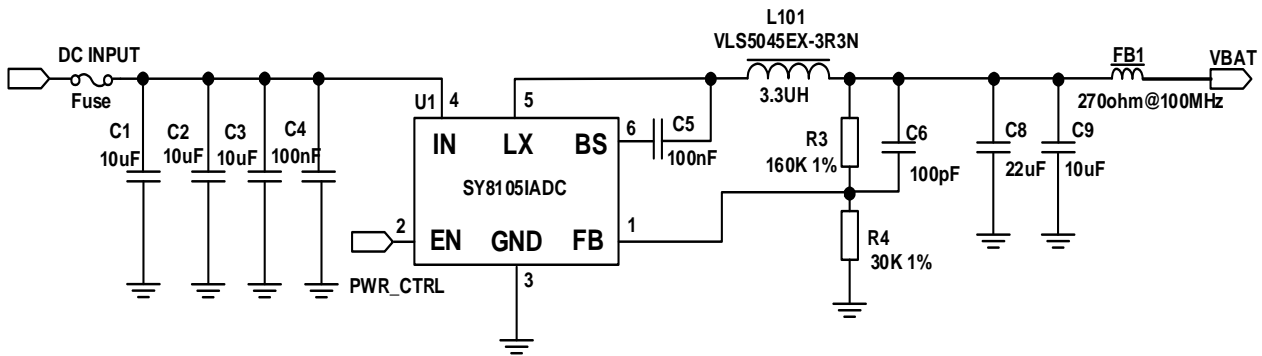

Figure 7: Switching mode power supply reference circuit

NOTE

1. In order to avoid damaging the module, please do not switch off the power supply when module works normally. Only after the module is shut down by FULL_CARD_POWER_OFF# or AT command, then the power supply can be cut off.
2. It is suggested that customer's design should have the ability to switch off the power supply for module in abnormal state, and then switch on the power to restart the module.

3.1.3 Voltage Monitor

To monitor the VBAT voltage, the AT command "AT+CBC" can be used.

NOTE

For the details about voltage monitor commands, please refer to [Document \[1\]](#) in the appendix.

3.2 Power On and Off Module

Driving the FULL_CARD_POWER_OFF# pin to a high level, SIM8200EA-M2 will be powered on. It can be driven by either 1.8V or 3.3V GPIO. The following figure shows the power on/off circuit.

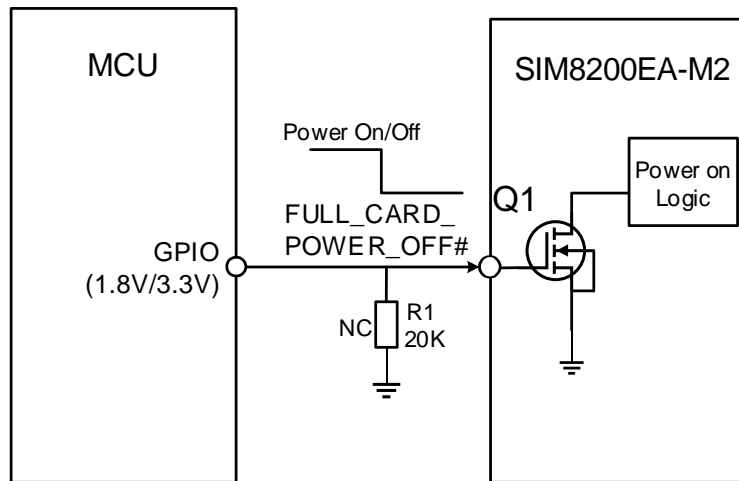

Figure 8: Reference power on/off circuit

Table 9: Definition of FULL_CARD_POWER_OFF# pin

Pin Name	Pin No.	Electrical Description	Description	Comment
FULL_CARD_POWER_OFF#	6	DI,PD	High level: the module powers on Low level: the module powers off	It's 3.3V tolerant but can be driven by either 1.8V or 3.3V GPIO

3.2.1 Power On

The power on sequence is shown in the following figure.

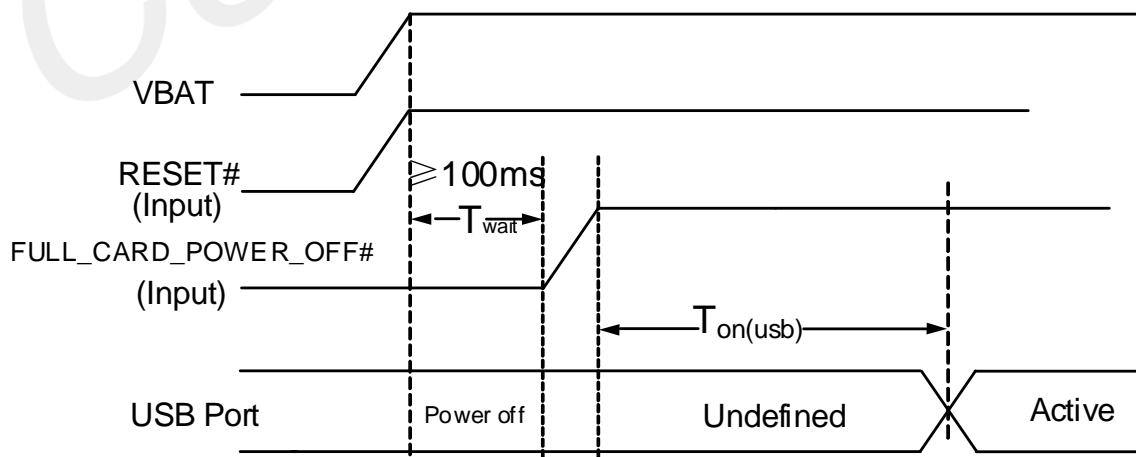

Figure 9: Power on sequence

Table 10: Power on timing and electrical characteristics

Symbol	Parameter	Min.	Typ.	Max.	Unit
T_{wait}	The waiting time from power supply available to power-on action	100	-	-	ms
$T_{on(usb)}$	The time from power-on action to USB port ready	-	TBD	-	s
V_{IH}	Input high level voltage on FULL_CARD_POWER_OFF# pin	1.2	1.8	4.4	V
V_{IL}	Input low level voltage on FULL_CARD_POWER_OFF# pin	0	-	0.2	V

3.2.2 Power Off

The following methods can be used to power off the module.

- Method 1: Power off the module by holding the FULL_CARD_POWER_OFF# pin to low level.
- Method 2: Power off module by AT command “AT+CPOF”.

NOTE

If the temperature is outside the range of $-30^{\circ}\text{C} \sim +70^{\circ}\text{C}$, some warning will be reported via AT port. If the temperature is outside the range of $-40^{\circ}\text{C} \sim +85^{\circ}\text{C}$, module will be powered off automatically. For the details about “AT+CPOF”, please refer to [Document \[1\]](#) in the appendix.

Above normal power-off action will make the module disconnect from the network, allow the software to enter a safe state, and save key data before the module is powered off completely.

The power off sequence is shown in the following figure.

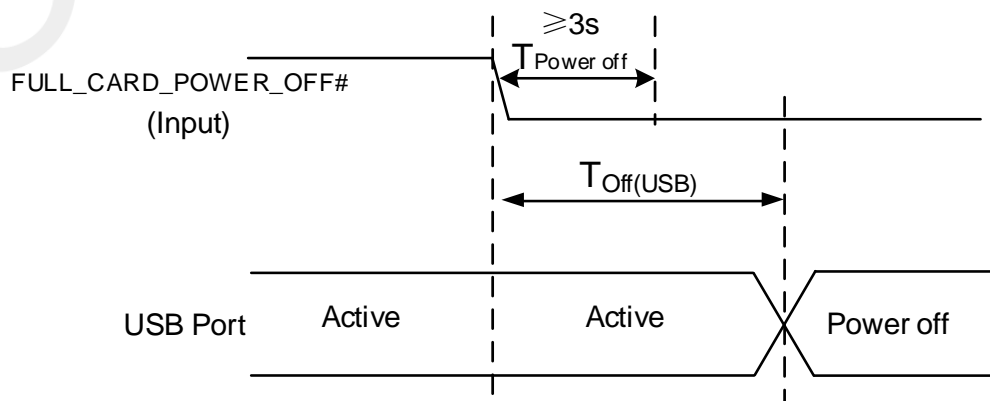

Figure 10: Power off sequence

Table 11: Power off timing and electrical characteristics

Symbol	Parameter	Time Value			Unit
		Min.	Typ.	Max.	
$T_{\text{Off(USB)}}$	The time from power-off action to USB port off	-	TBD	-	s
$T_{\text{Power off}}$	The time holding the FULL_CARD_POWER_OFF# pin to low level for the module into power off status	3	-	-	s

3.3 Reset Function

SIM8200EA-M2 can be reset by driving the RESET# pin down to a low level.

The RESET# signal has been internally pulled up to 1.8V, so it does not need pull up externally. Please refer to the following figure for the recommended reference circuit.

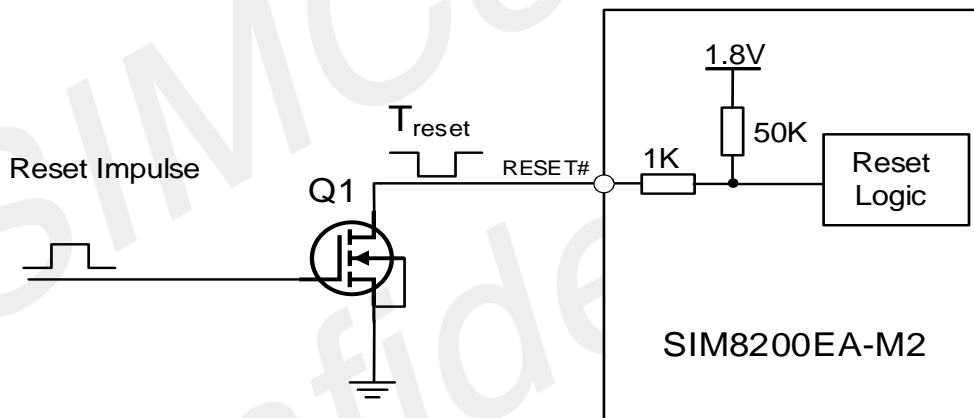

Figure 11: Reference reset circuit

Table 12: Definition of RESET# pin

Pin Name	Pin No.	Electrical Description	Description	Comment
RESET#	67	DI,PU	System reset control input Active low	RESET# has been pulled up to 1.8V internally

The reset timing sequence of the module is shown in the following figure.

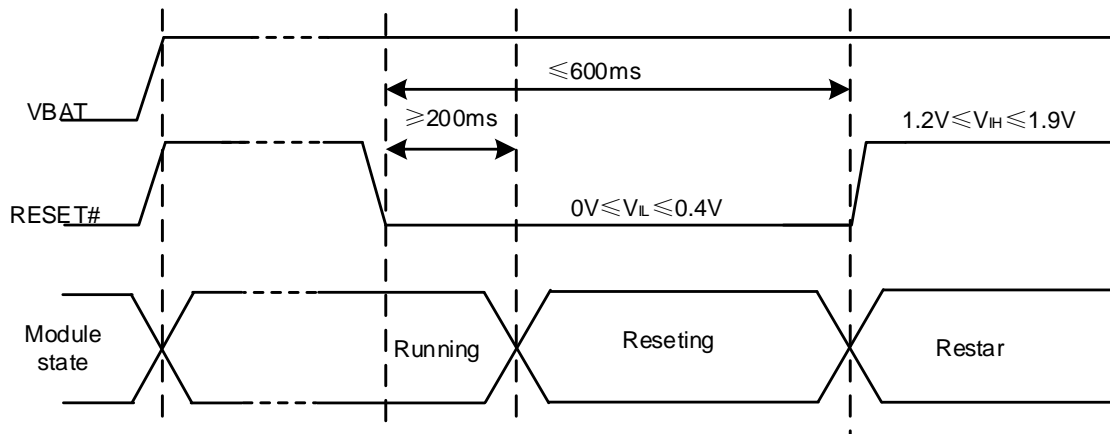

Figure 12: The reset timing sequence of the module

Table 13: RESET# pin electrical characteristics

Symbol	Description	Min.	Typ.	Max.	Unit
T_{reset}	Low level hold time on RESET# pin	200	-	600	ms
V_{IH}	Input high level voltage	1.2	-	1.9	V
V_{IL}	Input low level voltage	0	-	0.4	V

NOTE

Please ensure that there is no capacitance on RESET# pin.

3.4 I2C Interface

SIM8200EA-M2 supports an I2C interface meet I2C specification version 5.0, with data rate up to 400kpbs.

The following figure shows the I2C interface reference circuit.

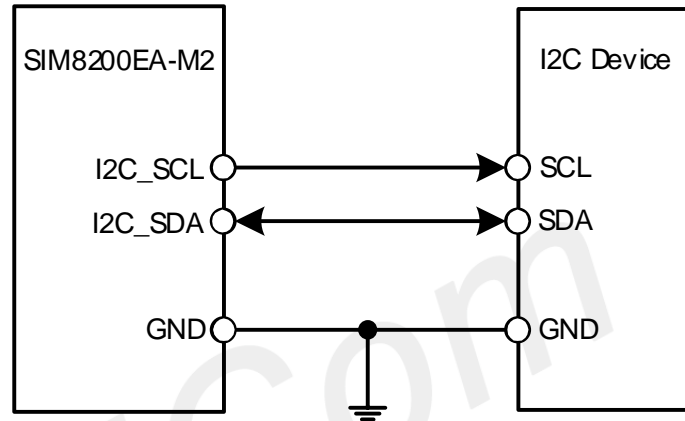

Figure 13: I2C reference circuit

Table 14: Definition of I2C interface

Pin Name	Pin No.	Electrical Description	Description	Comment
I2C_SDA	68	DIO	I2C data signal	1.8V voltage domain, Internal pulled up to 1.8V. If unused, please keep open
I2C_SCL	38	DO	I2C clock signal	

3.5 WoWWAN#*

The WoWWAN# pin is a system wake-on signal which can be used as an interrupt signal for the host. Normally it keeps high level. And it will change to low level when certain conditions occur, such as receiving SMS, voice call (CSD, video) or URC reporting, the low level pulse time is 1 second.

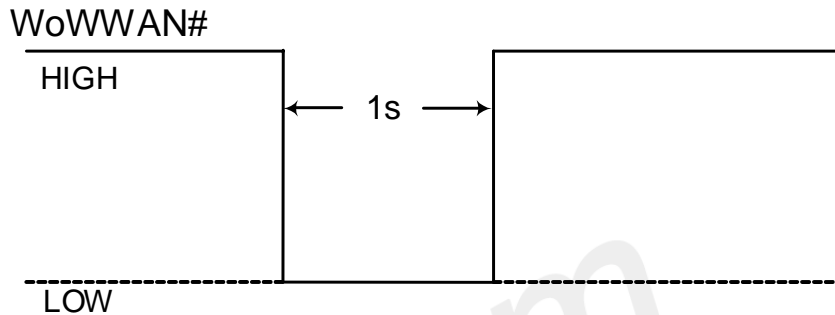

Figure 14: WoWWAN# signal level at SMS and URC report

WoWWAN# recommended reference circuit is shown in the following figure.

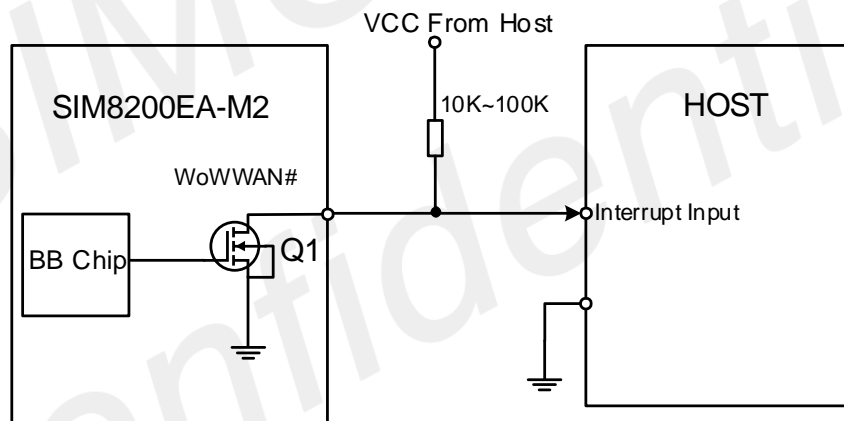

Figure 15: WoWWAN# reference circuit

Table 15: Definition of WoWWAN# pin

Pin Name	Pin No.	Electrical Description	Description	Comment
WoWWAN#	23	OD	Wake on the host Active low	

NOTE

“*” means under development.

3.6 USB Interface

SIM8200EA-M2 supports one USB interface which complies with the USB3.1 and 2.0 specifications. Customers can choose USB3.1 or USB2.0 for their needs. USB 3.1 data rate up to 10Gbps.

The USB interface is used for AT command communication, data transmission, GNSS NMEA output, firmware upgrade and software debugging.

The module supports USB suspend and resume mechanism which can save power consumption. If there is no data transmission on the USB bus, the module will enter suspend mode automatically.

The following figure is the USB reference circuit.

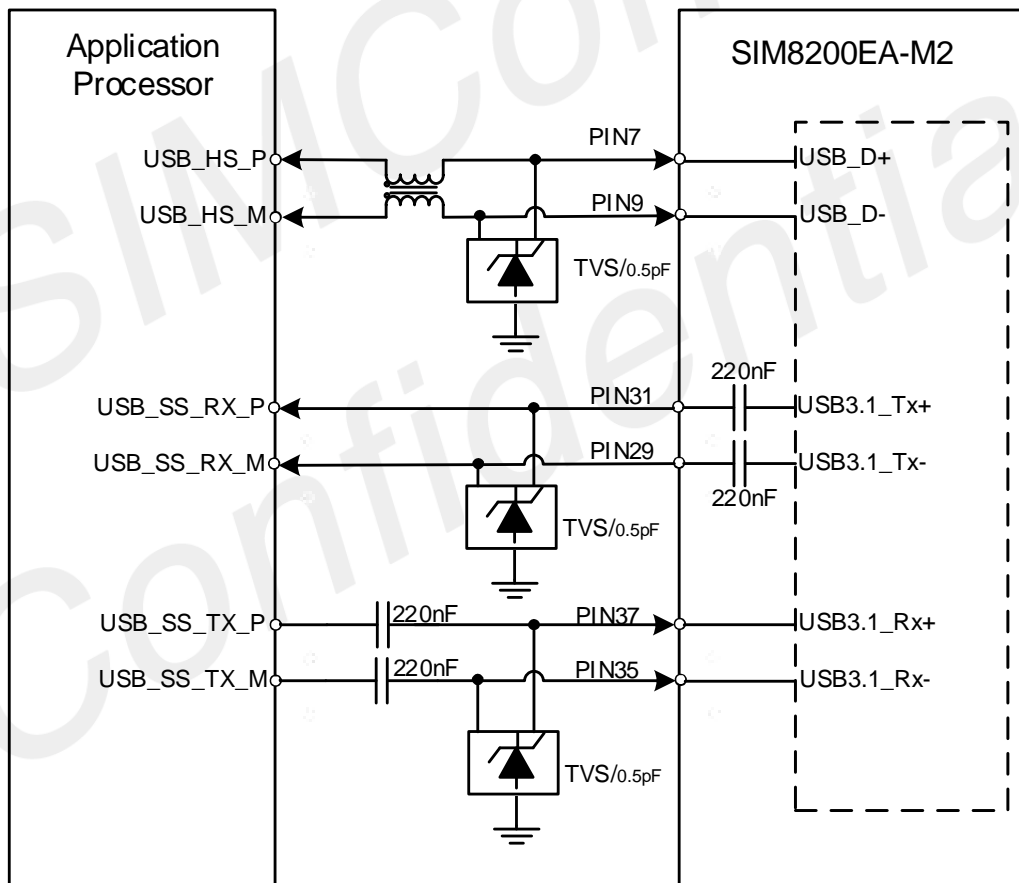

Figure 16: USB reference circuit

Table 16: Definition of USB interface

Pin Name	Pin No.	Electrical Description	Description	Comment
USB_D+	7	AIO	Differential USB bi-directional data positive	USB3.1 data rate up to 10Gbps USB2.0 data rate up to 480Mbps
USB_D-	9	AIO	Differential USB bi-directional data negative	
USB3.1_Tx-	29	AO	USB3.1 transmit data negative	
USB3.1_Tx+	31	AO	USB3.1 transmit data positive	
USB3.1_Rx-	35	AI	USB3.1 receive data negative	
USB3.1_Rx+	37	AI	USB3.1 receive data positive	

Table 17: USB interface recommended TVS diode list

No.	Manufacturer	Part Number	Package
1	WILL	ESD5302N-3/TR	DFN1006-3L

USB HS D+/D- layout guidelines:

- Require differential trace impedance is $90\pm 10\% \Omega$.
- The intra-lane length mismatch of the differential signal lanes is less than 1mm.
- Gap from other signals keeps 3xline width.
- External components should be placed near the USB connector.
- Trace routes away from other sensitive signals.
- The TVS diode should be placed close to the USB pins of M.2 connector.

USB SS TX/RX layout guidelines:

- Require differential trace impedance is $90\pm 10\% \Omega$.
- The intra-lane length mismatch of the differential signal lanes is less than 700um (5ps).
- Gap from other signals keeps 4xline width.
- Gap between Rx-to-Tx keeps 4xline width.
- External components should be placed near the USB connector.
- Trace routes away from other sensitive signals.
- The TVS diode should be placed close to the USB pins of M.2 connector.

3.7 PCIe Interface

SIM8200EA-M2 supports PCIe Gen3 one lane interfaces, which data rate up to 8Gbps, and can be used as EP or RC* mode. CLKREQ# and PEWAKE# needs pull up to 3.3V by 100K resistor in customers' design. The following figure is the PCIe reference circuit.

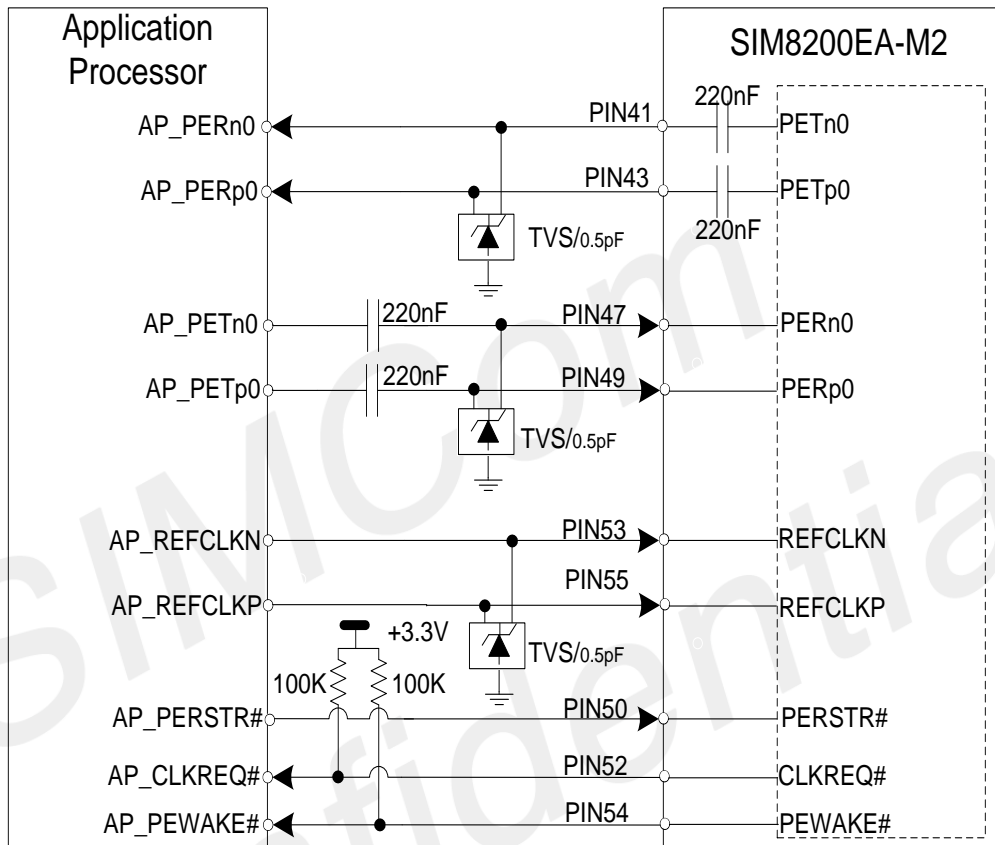

Figure 17: PCIe interface reference circuit (EP Mode)

NOTE

1. "*" means under development.
2. The AC capacitors of AP_PETn0 and AP_PETp0 should be closed to AP.
3. The voltage domain of PCIe assistant signals is 3.3V.

Table 18: Definition of PCIe interface

Pin Name	Pin No.	Electrical Description	Functional Description	Comment
PETn0	41	AO	PCIe transmit data negative	
PETp0	43	AO	PCIe transmit data positive	
PERn0	47	AI	PCIe receive data negative	
PERp0	49	AI	PCIe receive data positive	
REFCLKN	53	AIO	PCIe reference clock negative	
REFCLKP	55	AIO	PCIe reference clock positive	
PERSTR#	50	DI	PERSTR# is a functional reset to the Add-In module active low	3.3V voltage domain, CLKREQ# and PEWAKE# required pull up external, Default as EP mode. If unused, please keep open
CLKREQ#	52	DIO	PCIe reference clock request signal active low	
PEWAKE#	54	DIO	PCIe wake up signal active low	

Table 19: PCIe interface recommended TVS diode list

No.	Manufacturer	Part Number	Package
1	WILL	ESD5302N-3/TR	DFN1006-3L

PCIe interface layout guidelines:

- Require differential trace impedance is $90 \pm 10\% \Omega$.
- The intra-lane length mismatch of the differential signal lanes is less than 700um (5ps).
- Gap from other signals keeps 4xline width.
- Gap between Rx-to-Tx keeps 4xline width.
- Should be routed away from sensitive signals.
- The TVS diode should be placed close to the PCIe pins of M.2 connector.

3.8 (U)SIM Interface

SIM8200EA-M2 supports two (U)SIM cards but single standby. The (U)SIM2 can use e-(U)SIM* card in the module or external (U)SIM card, the size is 2mm*2mm*1mm of the e-(U)SIM. Both (U)SIM1 and (U)SIM2 are dual-voltage 1.8V or 3.0V.

NOTE

1. “*” means under development.
2. Customer choose the e-(U)SIM product in accordance with above size, SIMCom will provide the e-(U)SIM assemble into the module.

Table 20: (U)SIM electrical characteristics in 1.8V mode ((U)SIM_PWR=1.8V)

Symbol	Parameter	Min.	Typ.	Max.	Unit
(U)SIM_PWR	Power supply for (U)SIM card	1.65	1.8	1.95	V
V _{IH}	High-level input voltage	1.26	-	1.95	V
V _{IL}	Low-level input voltage	0	-	0.36	V
V _{OH}	High-level output voltage	1.44	-	1.8	V
V _{OL}	Low-level output voltage	0	-	0.4	V

Table 21: (U)SIM electrical characteristics in 3.0V mode ((U)SIM_PWR=3.0V)

Symbol	Parameter	Min.	Typ.	Max.	Unit
(U)SIM_PWR	Power supply for (U)SIM card	2.7	3.0	3.05	V
V _{IH}	High-level input voltage	2.1	-	3.05	V
V _{IL}	Low-level input voltage	0	0	0.6	V
V _{OH}	High-level output voltage	2.4	-	3.0	V
V _{OL}	Low-level output voltage	0	0	0.4	V

The module supports (U)SIM card hot-swap by the (U)SIM_DET pin, which is a level trigger pin. The (U)SIM_DET pin pulled up internally.

The following figure shows (U)SIM card reference circuit.

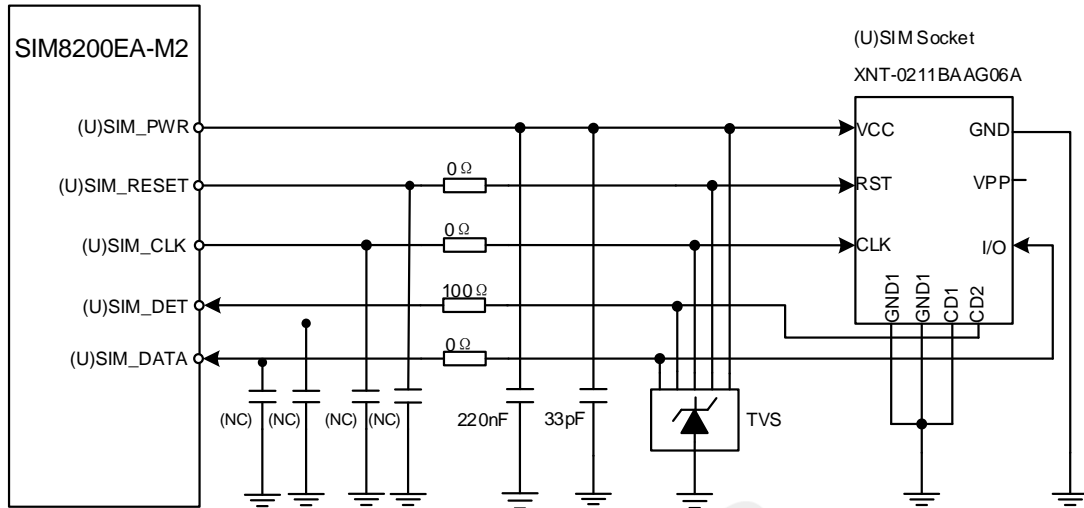

Figure 18: (U)SIM interface reference circuit

When the (U)SIM card is inserted, the (U)SIM_DET will change from high to low level. The falling edge will indicate insertion of the (U)SIM card. When the (U)SIM card is removed, the (U)SIM_DET will change from low to high level. This rising edge will indicate unplug the (U)SIM card.

The SIM card hot swap function needs to be enabled by AT. Please refer to the SIM8200 Series_AT Command Manual for the setting of the detection level of (U)SIM_DET pin.

Table 22: Definition of (U)SIM interface

Pin Name	Pin No.	Electrical Description	Description	Comment
(U)SIM1_PWR	36	PO	Power supply for (U)SIM1 card	
(U)SIM 1_DATA	34	DIO	(U)SIM1 card data, which has been pulled up to (U)SIM1_VDD via a 20KR resistor internally	
(U)SIM 1_CLK	32	DO	(U)SIM1 clock signal	
(U)SIM1_RESET	30	DO	(U)SIM1 Reset control	
(U)SIM 1_DET	66	DI	(U)SIM1 card detect, which has been pulled up to VDD_P3 via a 470KR resistor internally	1.8/3.0V voltage domain, all (U)SIM interfaces should be protected against ESD.
(U)SIM2_PWR	48	PO	Power supply for (U)SIM2 card	If unused, please keep open
(U)SIM2_DATA	42	DIO	(U)SIM2 card data, which has been pulled up to (U)SIM2_VDD via a 20KR resistor internally	
(U)SIM2_CLK	44	DO	(U)SIM2 clock signal	
(U)SIM2_RESET	46	DO	(U)SIM2 Reset control	
(U)SIM2_DET	40	DI	(U)SIM2 card detect, which has been pulled up to VDD_P3 via a 470KR resistor internally	

The following table shows recommended TVS of ESD protect and (U)SIM socket.

Table 23: Recommended TVS and (U)SIM socket list

Name	Manufacturer	Part Number
TVS	ST	ESDA6V1-5W6
(U)SIM socket	Suntech	XNT-0211BAAG06A

If the (U)SIM card hot-swap function is not used, customers can keep the (U)SIM_DET pin open.

The (U)SIM card layout guidelines:

- Make sure that the (U)SIM card holder should be far away from the antenna while in PCB layout.
- (U)SIM traces should keep away from RF lines, VBAT and high-speed signal lines.
- The traces should be as short as possible.
- Keep (U)SIM holder's GND connect to main ground directly.
- Shielding the (U)SIM card signal by ground.
- Recommended to place a 33pF ~ 1uF capacitor on (U)SIM_PWR line and keep close to the holder.
- The rise/fall time of (U)SIM_CLK should not be more than 40ns.
- The parasitic capacitance of TVS should not exceed 60pF and the TVS should be placed close to the (U)SIM socket.

3.9 I2S Interface

SIM8200EA-M2 supports one I2S interface for external codec, which follows the requirements in the Phillips I2S bus specification.

Table 24: I2S format

Characteristics	Specification
Line interface format	Linear(Fixed)
Data length	16bits(Fixed)
I2S clock/sync source	Master mode(Fixed)
I2S clock frequency	1.536MHz (Default)
I2S MCLK frequency	12.288MHz (Default)
Data ordering	MSB

NOTE

For the details about I2S AT commands, please refer to [document \[1\]](#) in the appendix.

3.9.1 I2S Timing

The module supports I2S sampling rate of 48 KHz and 32 bit coding signal (16 bit length), the timing sequence is shown in the following figure.

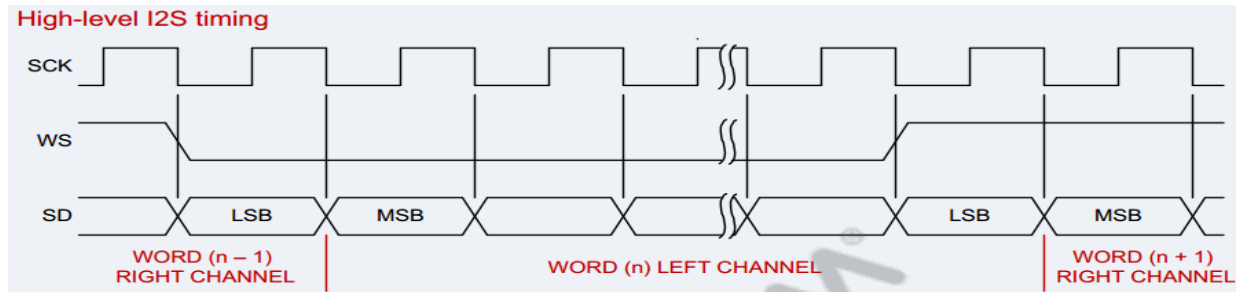

Figure 19: I2S timing

Table 25: I2S timing parameters

Signal	Parameter	Description	Min.	Typ.	Max.	Unit
I2S_MCLK	Frequency	Working Frequency	–	12.288	12.288	MHz
	T	Clock period	81.380	81.380	–	ns
	t(HC)	Clock high	0.45T	–	0.55T	ns
	t(LC)	Clock low	0.45T	–	0.55T	ns
I2S_CLK	Frequency	Working Frequency	8	48	48	KHz
	T	Clock period	20.83	20.83	125	us
	t(HC)	Clock high	0.45T	–	0.55T	ns
	t(LC)	Clock low	0.45T	–	0.55T	ns
I2S_WA	t(sr)	DIN/DOUT and WA input setup time	16.276	–	–	ns
	t(hr)	DIN/DOUT and WA input hold time	0	–	–	ns
	t(dtr)	DIN/DOUT and WA output delay	–	–	65.10	ns
	t(htr)	DIN/DOUT and WA output hold time	0	–	–	ns

3.9.2 I2S Reference Circuit

The following figure is the external codec reference design circuit.

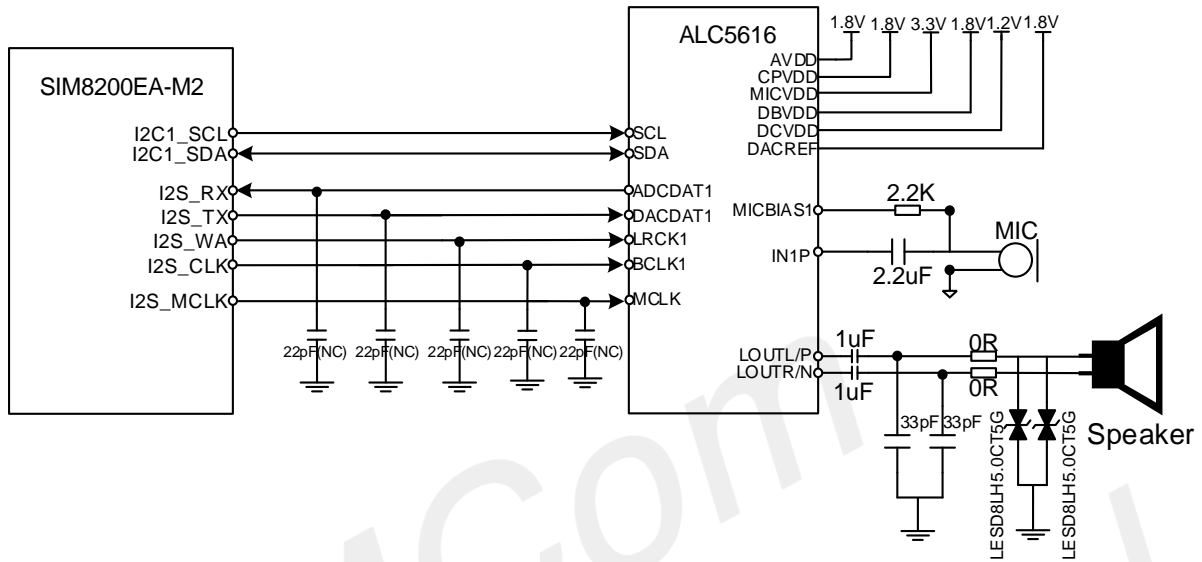

Figure 20: Audio codec reference circuit

Table 26: Definition of I2S interface

Pin Name	Pin No.	Electrical Description	Description	Comment
I2S_CLK	20	DO	I2S clock output	1.8V voltage domain, also can be used as PCM interface, If unused, please keep open
I2S_RX	22	DI	I2S data input	
I2S_TX	24	DO	I2S data output	
I2S_WA	28	DO	I2S word alignment select (L/R)	
I2S_MCLK	60	DO	I2S master clock	

The PCM interface is multiplexing with I2S interface. The default audio interface of the module is I2S.

Table 27: The PCM interface is multiplexing with I2S interface

Pin Name	PCM Interface
I2S_RX	PCM_DIN
I2S_TX	PCM_OUT
I2S_WA	PCM_SYNC
I2S_CLK	PCM_CLK
I2S_MCLK	-

Audio layout guidelines:

Analog input

- 0.2mm trace widths; 0.2mm spacing between other signals trace.
- Pseudo differential route for MIC.
- Isolate from noise sources, such as antenna, RF signals, SMPS, clocks, and other high speed signals.

Analog output

- Isolate from noise sources such as antenna, RF signals, SMPS, clocks, and other high speed signals.
- Speaker output signal – route as differential pair with 0.5mm trace widths.

SIMCom
Confidential

3.10 DPR*

DPR (Dynamic Power Reduction) signal is used for SAR (Specific Absorption Rate) requirements. The RF output power would reduce if this signal is triggered by sensor under some certain conditions, such as SAR sensor triggered, defined by customers.

User can activate this function with AT command.

Table 28: Definition of WoWWAN# pin

Pin No.	Pin Name	Pin Status	Function
25	DPR	Low	Max transmitting power will be reduced
		High	Max transmitting power will not be reduced (default)
		Floating	Max transmitting power will not be reduced

NOTE

“*” means under development.

3.11 CONFIG Pins

These signals are provided to indicate its specific configuration that is WWAN-USB3.1 of SIM8200EA-M2.

Table 29: CONFIG pins state of the module

Pin No.	Pin Name	Description
21	CONFIG_0	Connected to ground internally
69	CONFIG_1	Connected to ground internally
75	CONFIG_2	Connected to ground internally
1	CONFIG_3	Not connected

In the M.2 specifications, the CONFIG pins are defined as below.

Table 30: CONFIG interface definition

CONFIG_0 (Pin 21)	CONFIG_1 (Pin 69)	CONFIG_2 (Pin 75)	CONFIG_3 (Pin 1)	Module Type and Main Host Interface	Comments
GND	GND	GND	NC	WWAN – USB 3.1	Vendor defined

3.12 LED1#*

LED1# is open drain output and is used to allow SIM8200EA-M2 to provide network status via LED which will be provided by the host.

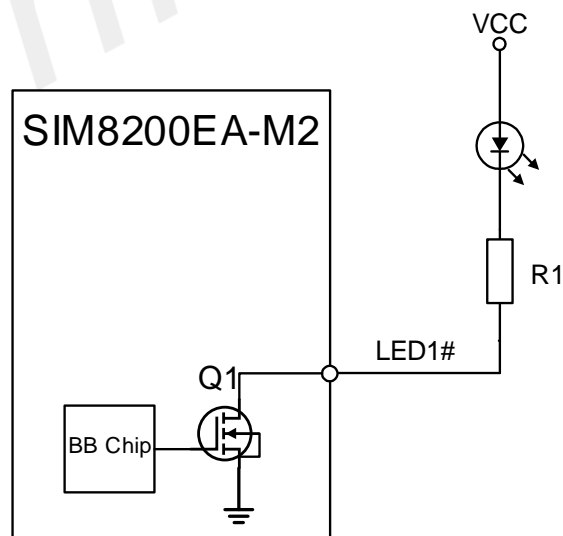

Figure 21: LED1# reference circuit

Table 31: Definition of LED1# pin

Pin Name	Pin No.	Electrical Description	Description	Comments
LED1#	10	OD	The module status indicator via LED devices Active low	

NOTE

1. “*” means under development.
2. The value of the resistor R1 depends on the LED characteristics.

The timing parameters are shown in the following table.

Table 32: LED1# pin status

LED1# Pin Status	Module Status
Always On	Searching network; call connection(including 5G,VOLTE)
100ms ON, 100ms OFF	Data transmit; 5G registered network
200ms ON, 200ms OFF	Data transmit; 4G registered network
800ms ON, 800ms OFF	Data transmit; 3G registered network
OFF	Power off ;Sleep mode

3.13 W_DISABLE1#

The W_DISABLE1# pin controls SIM8200EA-M2 to enter the flight mode. When the W_DISABLE1# signal is pulled to low level, RF function would be disabled. On the otherwise the RF function would be active. Recommended reference circuit is shown in the following figure.

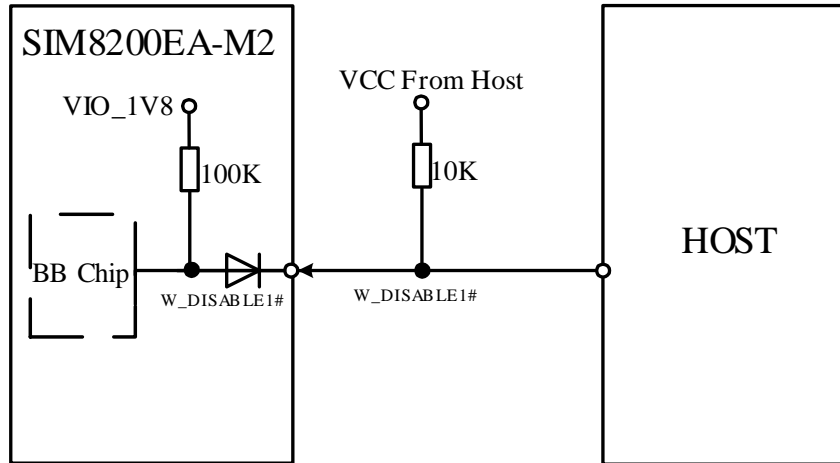

Figure 22: W_DISABLE1# pin reference circuit

Table 33: Definition of W_DISABLE1# pin

Pin Name	Pin No.	Electrical Description	Description	Comments
W_DISABLE1#	8	DI	WWAN RF disable Active low	3.3V tolerant but can be driven by either 1.8V or 3.3V GPIO

Table 34: W_DISABLE1# pin status

W_DISABLE1# Pin Status	Module Operation
Input low level	Flight mode: RF is disabled
Input high level	AT+CFUN=4: Flight mode AT+CFUN=1: RF is enabled (Default)

3.14 W_DISABLE2#*

The W_DISABLE2# pin controls SIM8200EA-M2 to disable the GNSS function. When the W_DISABLE2# signal is pulled to low level, the GNSS function would be disabled.

Recommended reference circuit is shown in the following figure.

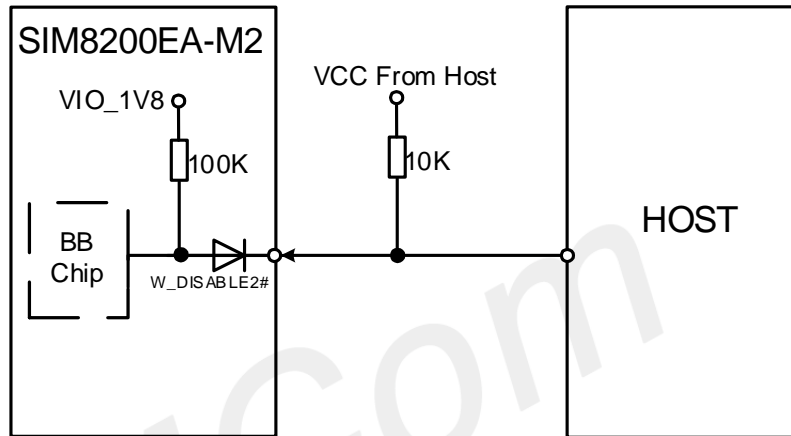

Figure 23: W_DISABLE2# pin reference circuit

Table 35: Definition of W_DISABLE2# pin

Pin Name	Pin No.	Electrical Description	Description	Comments
W_DISABLE2#	26	DI	GNSS disable Active low	3.3V tolerant but can be driven by either 1.8V or 3.3V GPIO

Table 36: W_DISABLE2# pin status

W_DISABLE2# Pin Status	Module Operation
Input Low Level	GNSS function is disabled
Input High Level	AT+CGPS=0: GNSS function is disabled AT+CGPS=1: GNSS function is enabled

NOTE

“*” means under development.

3.15 Antenna Control Interface*

ANTCTL[0:3] and RFFE signals are used for tunable antenna control and should be routed to an appropriate antenna control circuitry.

The following table are the definitions for antenn control interfaces.

Table 37: Definition of antenna control interface through GPIOs

Pin Name	Pin No.	Electrical Description	Description	Comments
ANTCTL0	59	DO	Antenna tuner control0	
ANTCTL1	61	DO	Antenna tuner control1	1.8V voltage domain. If unused, please keep open
ANTCTL 2 (RFFE_SDATA) ²	58	DO (DIO)	Antenna tuner control2 (Antenna tuner MIPI DATA) ²	
ANTCTL3 (RFFE_SCLK) ²	56	DO	Antenna tuner control3 (Antenna tuner MIPI CLK) ²	

NOTE

1. “*” means under development, for details please contact SIMCom support teams.
2. The RFFE signals are multiplexed with ANTCTL2 and ANTCTL3.

4. Antenna Interfaces

SIM8200EA-M2 provides six antenna interfaces, and all of them should be 50Ω impedance controlled for RF signal.

4.1 Antenna Definitions

Antenna interfaces are shown in the following figure.



Figure 24: Antenna interfaces

Table 38: Antenna port definitions

Item	ANT Function	Frequency Range	Function Description
ANT0	3G/4G/5G LB/MHB TRX 5G n41 UL/DL-MIMO1	617MHz~960MHz 1710MHz~2690MHz	3G/4G/5G signal send and receive
ANT1	4G UHB TRX 5G n41/n77/n78/n79 ¹ TRX	1710MHz~2690MHz 3300MHz~5000MHz	4G/5G signal send and receive
ANT2	3G/4G/5G LB/MHB DIV 5G n41 DL-MIMO2	617MHz~960MHz 1710MHz~2690MHz	3G/4G/5G signal receive
ANT3	3G/4G/5G MHB DL-MIMO1 4G UHB DIV 5G n41/n77/n78/n79 ¹ DIV	1710MHz~2690MHz 3300MHz~5000MHz	3G/4G/5G signal receive

ANT4	3G/4G/5G MHB DL-MIMO2 4G UHB DL-MIMO1 5G n77/n78/n79 ¹ DL-MIMO1	1710MHz~2690MHz 3300MHz~5000MHz	3G/4G/5G signal receive
ANT5	4G UHB DL-MIMO2 5G n77/n78/n79 ¹ DL-MIMO2 GNSS	3300MHz~5000MHz 1166MHz~1610MHz	4G/5G/GNSS signal receive

Table 39: SIM8200EA-M2 frequency band and antenna ports mapping

FUNCTIONS			ANTENNAS					
			ANT0	ANT1	ANT2	ANT3	ANT4	ANT5
3G/4G/5G	LB/MHB	TRX ²	✓					
5G	n41	UL/DL-MIMO1						
4G	UHB	TRX ²		✓				
5G	n41/n77/n78/n79 ¹	TRX ²						
3G/4G/5G	LB/MHB	DIV			✓			
5G	n41	DL-MIMO2						
3G/4G/5G	MHB	DL-MIMO1						
4G	UHB	DIV				✓		
5G	n41/n77/n78/n79 ¹	DIV						
3G/4G/5G	MHB	DL-MIMO2						
4G	UHB	DL-MIMO1					✓	
5G	n77/n78/n79 ¹	DL-MIMO1						
4G	UHB	DL-MIMO2						
5G	n77/n78/n79 ¹	DL-MIMO2						✓
GNSS								

NOTE

1. Default design can support 5G n77/n78, n79 support need another hardware variant.
2. For basic function, only the antennas responding to TRX are needed.

4.1.1 3G/4G/5G Operating Frequency

Table 40: The module operating frequency

Frequency Bands	Uplink (UL)	Downlink (DL)	Duplex Mode
WCDMA B1	1920 ~1980MHz	2110 ~2170MHz	FDD
WCDMA B2	1850~1910MHz	1930~1990MHz	FDD
WCDMA B3	1710 ~1785MHz	1805 ~1880MHz	FDD
WCDMA B4	1710 ~1755MHz	2110~ 2155MHz	FDD
WCDMA B5	824~849MHz	869~894MHz	FDD
WCDMA B8	880 ~915MHz	925 ~960MHz	FDD
LTE B1	1920 ~1980MHz	2110 ~2170MHz	FDD
LTE B2	1850~1910MHz	1930~1990MHz	FDD
LTE B3	1710 ~1785 MHz	1805 ~1880MHz	FDD
LTE B4	1710~1755MHz	2110~2155MHz	FDD
LTE B5	824~849 MHz	869~894MHz	FDD
LTE B7	2500~2570MHz	2620~2690MHz	FDD
LTE B8	880 ~915MHz	925 ~960MHz	FDD
LTE B12	699~716MHz	729~746MHz	FDD
LTE B13	777~787MHz	746~756MHz	FDD
LTE B14	788~798MHz	758~768MHz	FDD
LTE B17	704~716MHz	734~746MHz	FDD
LTE B18	815~830MHz	860~875MHz	FDD
LTE B19	830~845MHz	875~890MHz	FDD
LTE B20	832~862MHz	791~ 821MHz	FDD
LTE B25	1850~1915MHz	1930~1995MHz	FDD
LTE B26	814~849MHz	859~894MHz	FDD
LTE B28	703~748MHz	758~803MHz	FDD
LTE B29 ¹	/	717~728MHz	SDL
LTE B30	2305~2315MHz	2350~2360MHz	FDD
LTE B34	2010~2025MHz	2010~2025MHz	TDD
LTE B38	2570 ~2620MHz	2570 ~2620MHz	TDD
LTE B39	1880~1920MHz	1880~1920MHz	TDD
LTE B40	2300 ~2400MHz	2300 ~2400MHz	TDD
LTE B41	2496 ~2690MHz	2496 ~2690MHz	TDD
LTE B42	3400~3600MHz	3400~3600MHz	TDD
LTE B48	3550~3700MHz	3550~3700MHz	TDD
LTE B66	1710~1780MHz	2110~2180MHz	FDD
LTE B71	663~698MHz	617~652MHz	FDD
5G n1	1920 ~1980MHz	2110 ~2170MHz	FDD
5G n2	1850~1910MHz	1930~1990MHz	FDD

5G n3	1710 ~1785MHz	1805 ~1880MHz	FDD
5G n5	824~849MHz	869~894MHz	FDD
5G n7	2500~2570MHz	2620~2690MHz	FDD
5G n8	880 ~915MHz	925 ~960MHz	FDD
5G n12	699~716MHz	729~746MHz	FDD
5G n20	832~862MHz	791~ 821MHz	FDD
5G n25	1850~1915MHz	1930~1995MHz	FDD
5G n28	703~748MHz	758~803MHz	FDD
5G n40	2300 ~2400MHz	2300 ~2400MHz	TDD
5G n41	2496 ~2690MHz	2496 ~2690MHz	TDD
5G n66	1710~1780MHz	2110~2180MHz	FDD
5G n77	3300~4200MHz	3300~4200MHz	TDD
5G n78	3300~3800MHz	3300~3800MHz	TDD
5G n79 ²	4400~5000MHz	4400~5000MHz	TDD

NOTE

1. LTE-FDD B29 supports Rx only for secondary component carrier.
2. Default design can support 5G n77/n78, n79 support need another hardware variant.

4.1.2 GNSS Frequency

The following table shows frequency specifications of GNSS antenna interface.

Table 41: GNSS frequency

Type	Frequency
GPS L1/Galileo/QZSS	1575.42±1.023MHz
GPS L5	1176.45±10.23MHz
GLONASS	1597.5~1605.8MHz
BeiDou/Compass	1561.098±2.046MHz

4.2 Antenna Installation

4.2.1 Antenna Requirements

The following table shows the requirements on 3G/4G/5G antennas and GNSS antenna.

Table 42: 3G/4G/5G/GNSS antennas

Parameter	Requirement
Operating Frequency	See Table 38 for each antenna
Direction	Omni Directional
Gain	> -3dBi (Avg)
Impedance	50 Ω
Efficiency	> 50 %
Max. Input Power	50W
VSWR	< 2
Isolation	20dB is preferred
Cable Insertion Loss <1GHz	<1dB
Cable Insertion Loss 1GHz~2.2GHz	<1.5dB
Cable Insertion Loss 2.3GHz~2.7GHz	<2dB
Cable Insertion Loss 3.3GHz~6GHz	<2.5dB

Table 43: GNSS antenna (for dedicated GNSS antenna only)*

Parameter	Requirement
Operating Frequency	L1: 1559~1609MHZ L5: 1166~1187MHZ
Direction	Hemisphere, face to sky
Antenna Gain	> 2 dB _{ic}
Impedance	50 Ω
Efficiency	> 50 %
Max. Input Power	50W
VSWR	< 2
Polarization	RHCP or Linear
Noise Figure for Active Antenna	< 1.5
Total Gain for Active Antenna	< 17 dB
Cable Insertion Loss	<1.5dB

NOTE

*: These recommendations are for dedicated GNSS antenna which the application need best of class GNSS tracking performance.

4.2.2 RF Plug Recommendation

SIM8200EA-M2 is mounted with Murata's receptacle RF connectors MM4829-2702B/RA4/RB0, which size is 2.0mm*2.0mm*0.6mm. The connector dimensions are shown as below.

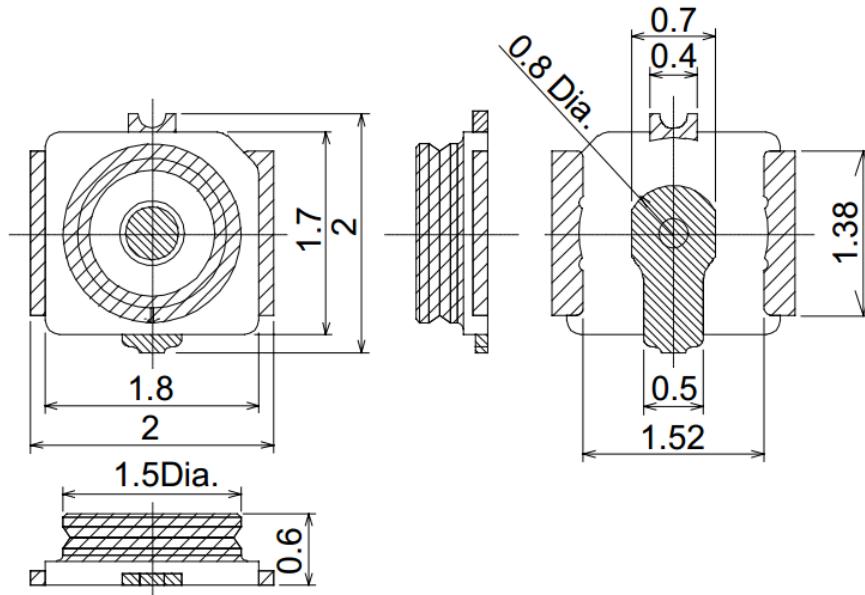

Figure 25: 3D view of MM4829-2702B/ RA4/ RBO

The following table shows the RF connector's electrical specifications.

Table 44: Electrical Specifications of MM4829-2702B/RA4/RB0

Item	Specification
Voltage Rating	250V r.m.s. maximum
Nominal Frequency Range	DC to 6GHz
Nominal Impedance	50Ω
Temperature Rating	-40°C to +85°C
Insulation Resistance	500 MΩ minimum
Withstanding Voltage	No evidence of breakdown
Initial Contact Resistance (without conductor resistance)	Center contact 20.0mΩmax. Outer contact 20.0mΩmax.
Voltage Standing Wave Ratio (V.S.W.R.)	Meet the requirements of 1.3max.(DC~3GHz) 1.45max.(3GHz~6GHz)

To get best RF performance, the RF plug connector should be designed to match the receptacle MM4829-2702B/RA4/RB0, and the parts come from Murata is the recommended.

The following is the mechanical information of the Murata's RF coaxial cable MXHJD3HJ1000 for reference.

For further technical support, the customer could visit the Murata's website (www.murata.com) or contact the local sales team.



Preliminary Specification of COAXIAL CONNECTOR

Preliminary SPEC No. : NMM04-PH0938A

Part Number : MXHJD3HJ1000

SPECIFICATION

1. MECHANICAL

Written by H. Toda
Checked by T. Kuriyama
Date 25/Jan./2018
Revised A: 26/Feb./19 IU

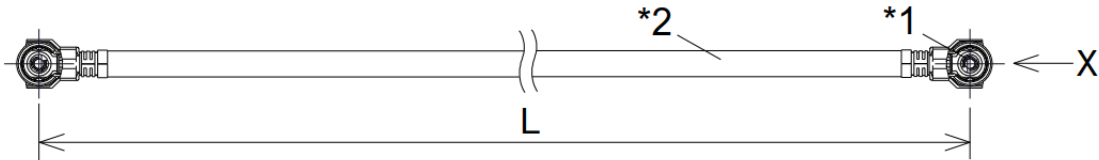

0 +/- 45 degree 
See X

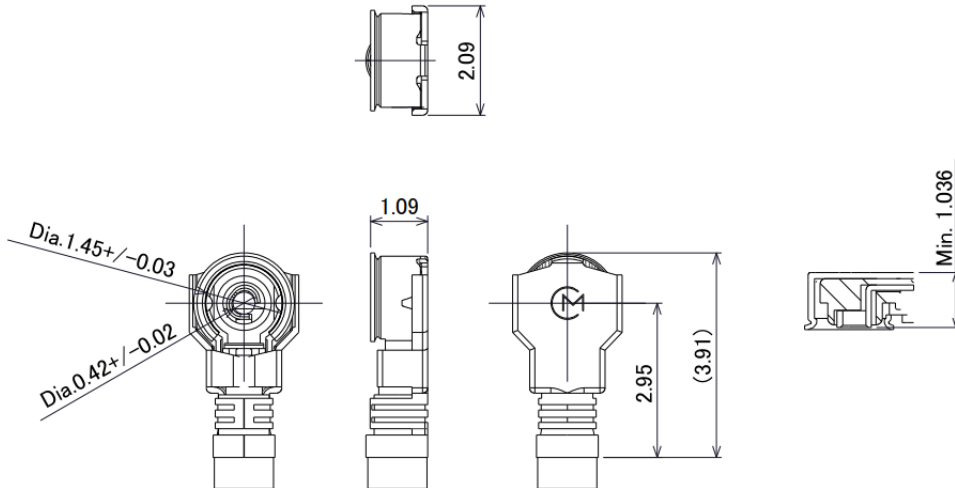

*1. Connector: HSC right angle plug connector
*2. Cable

Scale: Free
Tolerance Unless
Otherwise Specified: +/-0.3
Unit: mm

L
100 +/- 3

Figure 26: 3D view of MXHJD3HJ1000

5. Electrical Specifications

5.1 Absolute Maximum Ratings

Absolute maximum rating for digital and analog pins of module are listed in the following table.

Table 45: Absolute maximum ratings

Parameter	Min.	Typ.	Max.	Unit
Voltage at VBAT pins	-	-	4.8	V
Voltage at digital pins (GPIO,I2C,UART, I2S)	-	-	2.1	V
Voltage at digital pins ((U)SIM)	-	-	3.05	V
Voltage at FULL_CARD_POWER_OFF#	-	-	4.4	V
Voltage at RESET#	-	-	1.9	V

5.2 Operating Conditions

Table 46: VBAT recommended operating ratings

Parameter	Min.	Typ.	Max.	Unit
Voltage at VBAT	3.135	3.8	4.4	V

Table 47: 1.8V Digital I/O characteristics

Parameter	Description	Min.	Typ.	Max.	Unit
V _{IH}	High-level input voltage	1.17	-	2.1	V
V _{IL}	Low-level input voltage	0	-	0.63	V
V _{OH}	High-level output voltage	1.35	-	1.8	V
V _{OL}	Low-level output voltage	0	-	0.45	V
I _{OZH}	High-level, tri-state leakage current (no pull down resistor)	-	-	1	uA
I _{OZL}	Low-level, tri-state leakage current (no pull up resistor)	-1	-	-	uA

I_{IH}	Input high leakage current (no pull down resistor)	-	-	1	uA
I_{IL}	Input low leakage current(no pull up resistor)	-1	-	-	uA

Table 48: Operating temperature

Parameter	Min.	Typ.	Max.	Unit
Normal operation temperature(3GPP compliant)	-30	-	70	°C
Extended operation temperature*	-40	-	85	°C
Storage temperature	-40	-	90	°C

5.3 Operating Mode

5.3.1 Operating Mode Definition

The table below summarizes the various operating modes of SIM8200EA-M2.

Table 49: Operating mode definition

Mode	Function
Normal operation	UMTS/LTE/5G Sleep AT command “AT+CSCLK=1” can be used to set the module to a sleep mode. In this case, the current consumption of module will be reduced to a very low level and the module can still receive paging message and SMS.
	UMTS/LTE/5G Idle Software is active. Module is registered to the network, and ready to communicate.
	UMTS/LTE/5G Talk Connection between two subscribers is in progress. In this case, the power consumption depends on network settings such as DTX off/on, FR/EFR/HR, hopping sequences, and antennas.
	UMTS/LTE/5G Standby Module is ready for data transmission, but no data is currently sent or received. In this case, power consumption depends on network settings.
	UMTS/LTE/5G Data transmission There is data transmission in progress. In this case, power consumption is related to network settings (e.g. power control level); uplink/downlink data rates, etc.
Minimum functionality mode	AT command “AT+CFUN=0” can be used to set the module to a minimum functionality mode without removing the power supply. In this mode, the RF part of the module will not work and the (U)SIM card will not be accessible, but the serial port and USB port are still accessible. The power consumption in this mode is lower than normal mode.
Flight mode	AT command “AT+CFUN=4” or pulling down the W_disable1# pin can

	be used to set the module to flight mode without removing the power supply. In this case, the RF part of the module will not work, but the serial port and USB are still available. The power consumption is lower than normal mode.
Power off	Normally module will go into power off mode by sending the AT command "AT+CPOF" or pull down the FULL_CARD_POWER_OFF# pin. In this mode the power management unit shuts down the power supply, and software is not active. The serial port and USB are not available.

5.3.2 Sleep Mode

In sleep mode, the current consumption of the module will be reduced to a very low level.

Several hardware and software conditions must be satisfied in order to let module enter into sleep mode:

1. UART condition
2. USB condition
3. Software condition

NOTE

Before designing, pay attention to how to realize sleeping/waking function.

5.3.3 Minimum Functionality Mode and Flight Mode

Minimum functionality mode ceases a majority of functions of the module, in order to minimize the power consumption. This mode is set by the AT command which provides a choice of 3 different functionality levels.

- AT+CFUN=0: Minimum functionality
- AT+CFUN=1: Full functionality (Default)
- AT+CFUN=4: Flight mode

If module has been set to minimum functionality mode, the RF (U)SIM card functions will be closed while the serial port and USB are still available.

If module has been set to flight mode, the RF function will be closed while the (U)SIM card, the serial port and USB are still available.

When module is in minimum functionality or flight mode, it can return to full functionality by the AT command "AT+CFUN=1".

5.4 Current Consumption

The current consumptions are listed in the table below.

Table 50: Current consumption on VBAT pins (VBAT=3.8V)

GNSS			
GNSS supply current (AT+CFUN=0,with USB connection)	@ -140dBm, Tracking Typical:60mA		
UMTS Sleep/Idle Mode			
WCDMA supply current (GNSS off, without USB connection)	Sleep mode @DRX=9 Typical: TBD Idle mode @DRX=9 Typical: 34mA		
LTE Sleep/Idle Mode			
LTE FDD supply current (GNSS off, without USB connection)	Sleep mode Typical: TBD Idle mode Typical: 38mA		
LTE TDD supply current (GNSS off, without USB connection)	Sleep mode Typical: TBD Idle mode Typical: 36mA		
UMTS Talk			
WCDMA B1	@Power 23dBm Typical: TBD		
WCDMA B2	@Power 23dBm Typical: TBD		
WCDMA B3	@Power 23dBm Typical: TBD		
WCDMA B4	@Power 23dBm Typical: TBD		
WCDMA B5	@Power 23dBm Typical: TBD		
WCDMA B8	@Power 23dBm Typical: TBD		
HSDPA Data			
WCDMA B1	@Power 23dBm Typical: TBD		
WCDMA B2	@Power 23dBm Typical: TBD		
WCDMA B3	@Power 23dBm Typical: TBD		
WCDMA B4	@Power 23dBm Typical: TBD		
WCDMA B5	@Power 23dBm Typical: TBD		
WCDMA B8	@Power 23dBm Typical: TBD		
LTE Data			
LTE-FDD B1	@5MHz	23dBm	Typical :TBD
	@10MHz	23dBm	Typical :TBD
	@20MHz	23dBm	Typical :TBD
LTE-FDD B2	@5MHz	23dBm	Typical :TBD
	@10MHz	23dBm	Typical :TBD
	@20MHz	23dBm	Typical :TBD
LTE-FDD B3	@5MHz	23dBm	Typical :TBD
	@10MHz	23dBm	Typical :TBD
	@20MHz	23dBm	Typical :TBD
LTE-FDD B4	@5MHz	23dBm	Typical :TBD
	@10MHz	23dBm	Typical :TBD
	@20MHz	23dBm	Typical :TBD
LTE-FDD B5	@5MHz	23dBm	Typical :TBD
	@10MHz	23dBm	Typical :TBD

LTE-FDD B7	@5MHz 23dBm @10MHz 23dBm @20MHz 23dBm	Typical :TBD Typical :TBD Typical :TBD
LTE-FDD B8	@5MHz 23dBm @10MHz 23dBm	Typical :TBD Typical :TBD
LTE-FDD B12	@5MHz 23dBm @10MHz 23dBm	Typical :TBD Typical :TBD
LTE-FDD B13	@5MHz 23dBm @10MHz 23dBm	Typical :TBD Typical :TBD
LTE-FDD B14	@5MHz 23dBm @10MHz 23dBm	Typical :TBD Typical :TBD
LTE-FDD B17	@5MHz 23dBm @10MHz 23dBm	Typical :TBD Typical :TBD
LTE-FDD B18	@5MHz 23dBm @10MHz 23dBm	Typical :TBD Typical :TBD
LTE-FDD B19	@5MHz 23dBm @10MHz 23dBm	Typical :TBD Typical :TBD
LTE-FDD B20	@5MHz 23dBm @10MHz 23dBm @20MHz 23dBm	Typical :TBD Typical :TBD Typical :TBD
LTE-FDD B25	@5MHz 23dBm @10MHz 23dBm @20MHz 23dBm	Typical :TBD Typical :TBD Typical :TBD
LTE-FDD B26	@5MHz 23dBm @10MHz 23dBm	Typical :TBD Typical :TBD
LTE-FDD B28	@5MHz 23dBm @10MHz 23dBm @20MHz 23dBm	Typical :TBD Typical :TBD Typical :TBD
LTE-FDD B30	@5MHz 23dBm @10MHz 23dBm	Typical :TBD Typical :TBD
LTE-TDD B34	@5MHz 23dBm @10MHz 23dBm	Typical :TBD Typical :TBD
LTE-TDD B38	@5MHz 23dBm @10MHz 23dBm @20MHz 23dBm	Typical :TBD Typical :TBD Typical :TBD
LTE-TDD B39	@5MHz 23dBm @10MHz 23dBm @20MHz 23dBm	Typical :TBD Typical :TBD Typical :TBD
LTE-TDD B40	@5MHz 23dBm @10MHz 23dBm @20MHz 23dBm	Typical :TBD Typical :TBD Typical :TBD
LTE-TDD B41	@5MHz 23dBm @10MHz 23dBm @20MHz 23dBm	Typical :TBD Typical :TBD Typical :TBD
LTE-TDD B42	@5MHz 23dBm @10MHz 23dBm @20MHz 23dBm	Typical :TBD Typical :TBD Typical :TBD
LTE-TDD B48	@5MHz 23dBm @10MHz 23dBm @20MHz 23dBm	Typical :TBD Typical :TBD Typical :TBD

NR Data

5G n1	@Power 23dBm Typical: TBD
5G n2	@Power 23dBm Typical: TBD
5G n3	@Power 23dBm Typical: TBD
5G n5	@Power 23dBm Typical: TBD
5G n7	@Power 23dBm Typical: TBD

5G n8	@Power 23dBm Typical: TBD
5G n12	@Power 23dBm Typical: TBD
5G n20	@Power 23dBm Typical: TBD
5G n25	@Power 23dBm Typical: TBD
5G n28	@Power 23dBm Typical: TBD
5G n40	@Power 23dBm Typical: TBD
5G n41	@Power 23dBm Typical: TBD
5G n66	@Power 23dBm Typical: TBD
5G n71	@Power 23dBm Typical: TBD
5G n77	@Power 23dBm Typical: TBD
5G n78	@Power 23dBm Typical: TBD
5G n79 ¹	@Power 23dBm Typical: TBD

NOTE

1. Default design can support 5G n77/n78, n79 support need another hardware variant.

5.5 RF Output Power

The RF output power is shown in the following table.

Table 51: Conducted output power

Bands	Max	Min
WCDMA Bands	23dBm + 1/-3dB	< -50dBm
LTE-FDD Bands	23dBm + 2/-2dB	< -40dBm
LTE-TDD Bands	23dBm + 2/-2dB	< -40dBm
5G Sub-6 Bands	23dBm + 2/-2dB	< -40dBm

5.6 Conducted Receive Sensitivity

The conducted RF receiving sensitivity is shown in the following table.

Table 52: Conducted RF receiving sensitivity

Frequency	Primary (Typ.)	Diversity (Typ.)	SIMO1(Typ.)	SIMO2(Worst Case)
WCDMA B1	TBD	TBD	TBD	-106.7dBm
WCDMA B2	TBD	TBD	TBD	-103.7dBm
WCDMA B3	TBD	TBD	TBD	-104.7dBm
WCDMA B4	TBD	TBD	TBD	-103.7dBm
WCDMA B5	TBD	TBD	TBD	-96.3dBm
WCDMA B8	TBD	TBD	TBD	-93.3dBm
LTE B1	TBD	TBD	TBD	-94.3dBm
LTE B2	TBD	TBD	TBD	-94.3dBm
LTE B3	TBD	TBD	TBD	-93.3dBm
LTE B4	TBD	TBD	TBD	-93.3dBm
LTE B5	TBD	TBD	TBD	-94.8dBm
LTE B7	TBD	TBD	TBD	-96.3dBm
LTE B8	TBD	TBD	TBD	-96.3dBm
LTE B12	TBD	TBD	TBD	-94.3dBm
LTE B13	TBD	TBD	TBD	-93.3dBm
LTE B14	TBD	TBD	TBD	-93.3dBm
LTE B17	TBD	TBD	TBD	-93.3dBm
LTE B18	TBD	TBD	TBD	-96.3dBm
LTE B19	TBD	TBD	TBD	-96.3dBm
LTE B20	TBD	TBD	TBD	-93.3dBm
LTE B25	TBD	TBD	TBD	-92.8dBm
LTE B26	TBD	TBD	TBD	-93.8dBm
LTE B28	TBD	TBD	TBD	-94.8dBm
LTE B29	TBD	TBD	TBD	-93.3dBm
LTE B30	TBD	TBD	TBD	-95.3dBm
LTE B34	TBD	TBD	TBD	-96.3dBm
LTE B38	TBD	TBD	TBD	-96.3dBm
LTE B39	TBD	TBD	TBD	-96.3dBm
LTE B40	TBD	TBD	TBD	-96.3dBm
LTE B41	TBD	TBD	TBD	-94.3dBm
LTE B42	TBD	TBD	TBD	-95.0dBm
LTE B48	TBD	TBD	TBD	TBD
5G n1	TBD	TBD	TBD	-97.1dBm

5G n2	TBD	TBD	TBD	-95.1dBm
5G n3	TBD	TBD	TBD	-94.1dBm
5G n5	TBD	TBD	TBD	-95.1dBm
5G n7	TBD	TBD	TBD	-95.1dBm
5G n8	TBD	TBD	TBD	-94.1dBm
5G n12	TBD	TBD	TBD	-94.1dBm
5G n20	TBD	TBD	TBD	-94.1dBm
5G n25	TBD	TBD	TBD	-93.6dBm
5G n28	TBD	TBD	TBD	-95.6dBm
5G n40	TBD	TBD	TBD	-97.1dBm
5G n41	TBD	TBD	TBD	-95.1dBm
5G n66	TBD	TBD	TBD	-96.6dBm
5G n71	TBD	TBD	TBD	-94.3dBm
5G n77	TBD	TBD	TBD	-94.1dBm
5G n78	TBD	TBD	TBD	-94.1dBm
5G n79 ¹	TBD	TBD	TBD	TBD

NOTE

1. Default design can support 5G n77/n78, n79 support need another hardware variant.

5.7 Thermal Design

Make sure that the SIM8200EA-M2 can reach maximum work performance under extended temperature or extreme conditions for a long time, thermal dissipation design is very important.

It is strongly recommended to add a thermal pad or other thermally conductive material between the module and the main PCB. The thermal dissipation area on bottom side of the module and the dimensions is shown in the following figure. The dimensions are measured in mm.

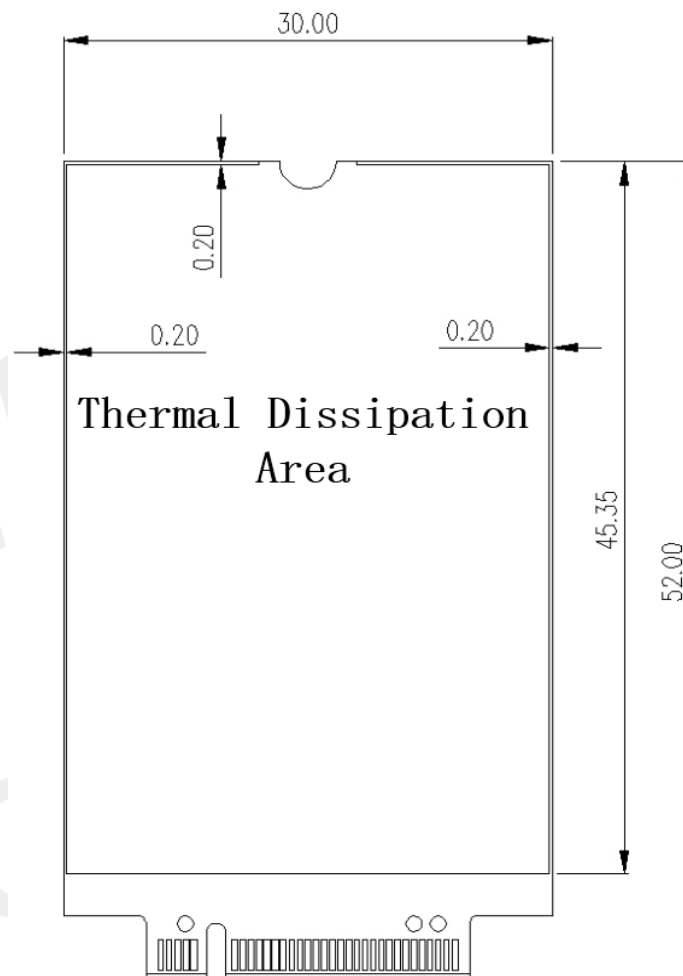

Figure 27: Thermal dissipation area on bottom side of the module

There are some design rules to enhance thermal dissipation performance:

- Keep the module away from other heat sources such as battery, power, AP, etc.
- Make sure that the module mounting holes connect to the main PCB ground fully.
- Add enough through via on the main PCB. Via material is very important solid copper and stacked via is better.
- Make sure maximize airflow around the module.
- Recommend use heat dissipation material connect to the customers' device on the top side of the module to enhance the heat dissipation. Large heat dissipation area is better.
- Chose a high effective heat dissipation material is better such as heat pipe, graphite sheets.

5.8 ESD

SIM8200EA-M2 is sensitive to ESD in the process of storage, transporting, and assembling. When module is mounted on the users' mother board, the ESD components should be placed beside the connectors which human body may touch, such as (U)SIM card holder, SD card holder, audio jacks, switches, USB interface, etc. The following table shows the module ESD test performance.

Table 53: The ESD performance measurement table (Temperature: 25°C, Humidity: 45%)

Part	Contact Discharge	Air Discharge
VBAT,GND	+/- 4KV	+/- 10KV
Antenna	+/- 5KV	+/- 10KV
FULL_CARD_POWER_OFF#	+/- 4KV	+/- 8KV
USB	+/- 4KV	+/- 8KV
RESET#	+/- 3KV	+/- 6KV
(U)SIM	+/- 3KV	+/- 6KV
Other PAD	+/- 3KV	+/- 6KV

NOTE

Test conditions: the external of the module has surge protection diodes and ESD protection diodes

6. Appearance

6.1 Top and Bottom View of SIM8200EA-M2

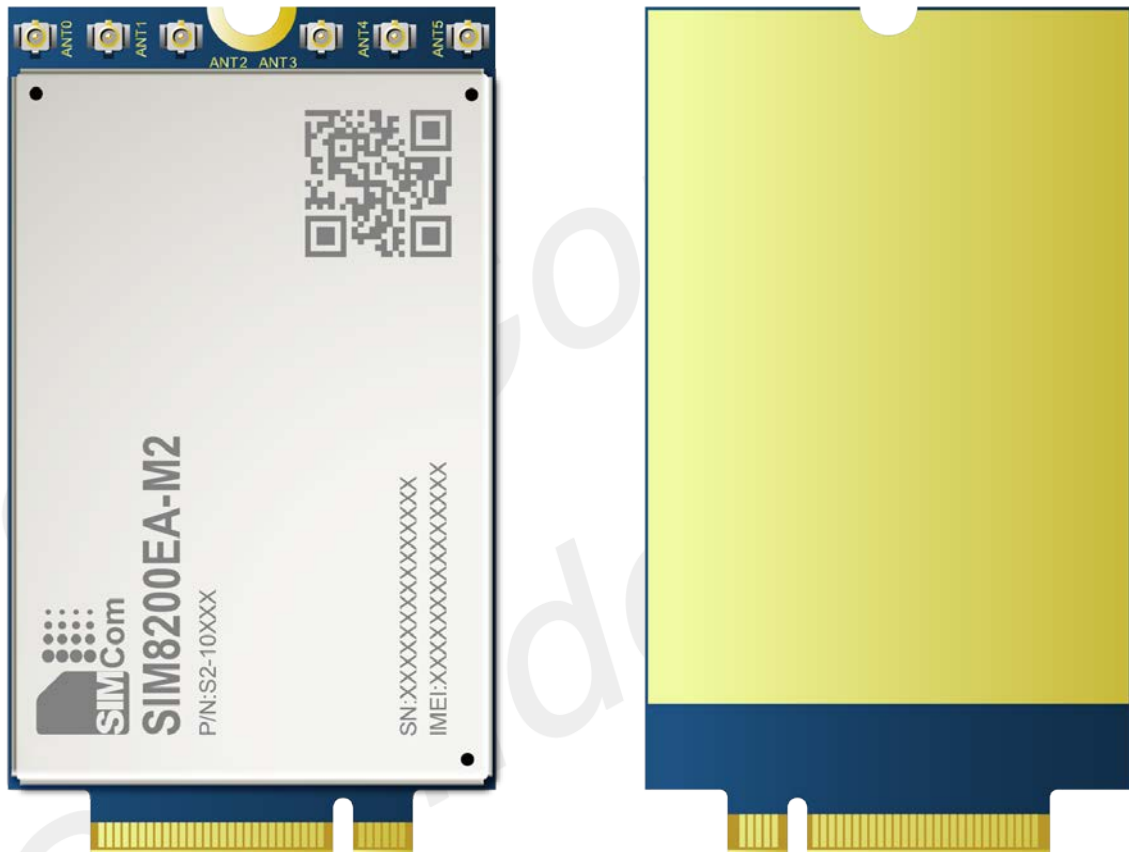

Figure 28: Top and bottom view of the module

6.2 Label Description Information

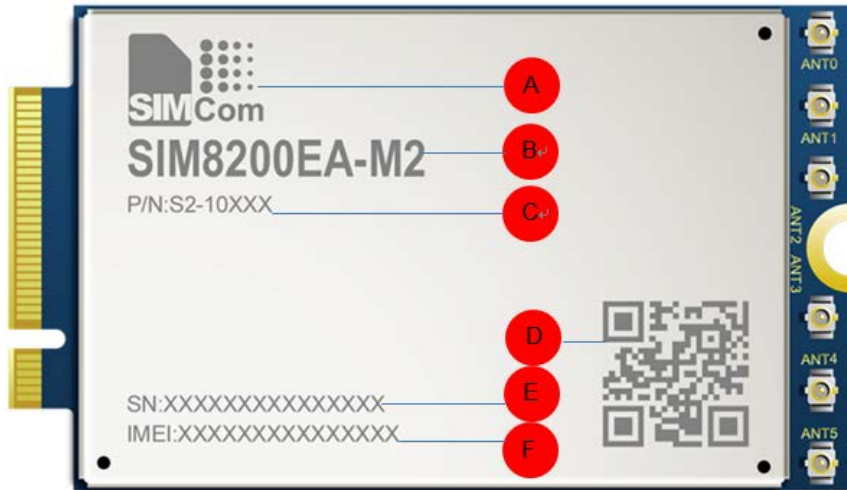

Figure 29: Label description of the module

Table 54: Label description of the module information

No.	Description
A	LOGO
B	Project name
C	Product code
D	QR code
E	Serial number
F	International mobile equipment identity

7. Packaging

SIM8200EA-M2 supports tray packaging. The packaging procedures are shown in the following figure.

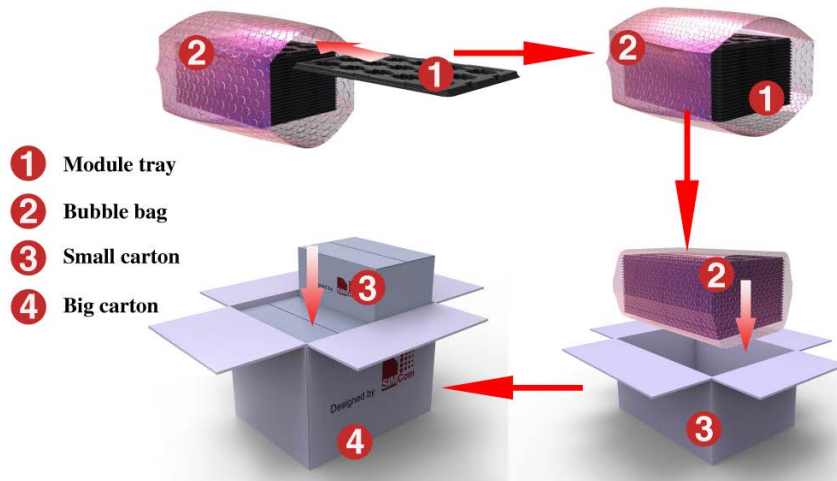

Figure 30: Packaging procedures

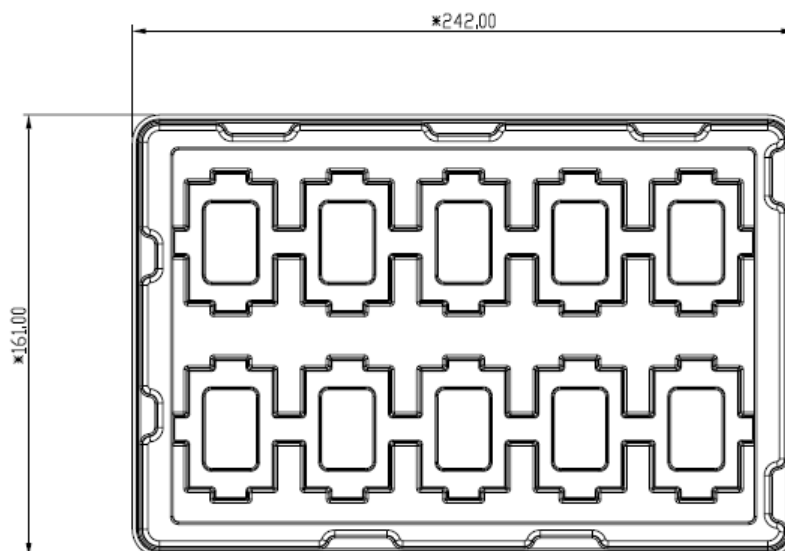

Figure 31: Tray view of the module

Table 55: Tray size

Length ($\pm 3\text{mm}$)	Width ($\pm 3\text{mm}$)	Number
245.0	165.0	10

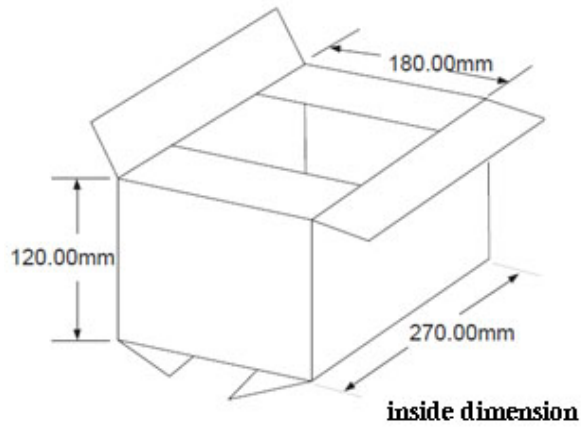

Figure 32: Small carton view

Table 56: Small carton size

Length ($\pm 10\text{mm}$)	Width ($\pm 10\text{mm}$)	Height ($\pm 10\text{mm}$)	Number
270	180	120	10*20=200

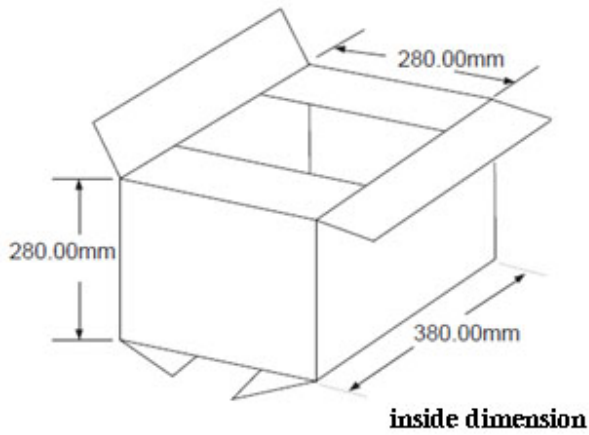

Figure 33: Big carton view

Table 57: Big carton size

Length ($\pm 10\text{mm}$)	Width ($\pm 10\text{mm}$)	Height ($\pm 10\text{mm}$)	Number
380	280	280	200*4=800

8. Appendix

8.1 Coding Schemes and Maximum Net Data Rates over Air Interface

Table 58: Coding schemes and maximum net data rates over air interface

HSDPA Device Category	Max Data Rate (Peak)	Modulation Type
Category 1	1.2Mbps	16QAM,QPSK
Category 2	1.2Mbps	16QAM,QPSK
Category 3	1.8Mbps	16QAM,QPSK
Category 4	1.8Mbps	16QAM,QPSK
Category 5	3.6Mbps	16QAM,QPSK
Category 6	3.6Mbps	16QAM,QPSK
Category 7	7.2Mbps	16QAM,QPSK
Category 8	7.2Mbps	16QAM,QPSK
Category 9	10.2Mbps	16QAM,QPSK
Category 10	14.4Mbps	16QAM,QPSK
Category 11	0.9Mbps	QPSK
Category 12	1.8Mbps	QPSK
Category 13	17.6Mbps	64QAM
Category 14	21.1Mbps	64QAM
Category 15	23.4Mbps	16QAM
Category 16	28Mbps	16QAM
Category 17	23.4Mbps	64QAM
Category 18	28Mbps	64QAM
Category 19	35.5Mbps	64QAM
Category 20	42Mbps	64QAM
Category 21	23.4Mbps	16QAM
Category 22	28Mbps	16QAM
Category 23	35.5Mbps	64QAM
Category 24	42.2Mbps	64QAM
HSUPA Device Category	Max Data Rate (Peak)	Modulation Type
Category 1	0.96Mbps	QPSK
Category 2	1.92Mbps	QPSK
Category 3	1.92Mbps	QPSK
Category 4	3.84Mbps	QPSK
Category 5	3.84Mbps	QPSK

Category 6	5.76Mbps	QPSK
LTE-FDD Device Category (Downlink)		
LTE-FDD Device Category (Downlink)	Max Rate Rate (Peak)	Modulation Type
Category 1	10Mbps	QPSK/16QAM/64QAM
Category 2	50Mbps	QPSK/16QAM/64QAM
Category 3	100Mbps	QPSK/16QAM/64QAM
Category 4	150Mbps	QPSK/16QAM/64QAM
Category 5	300Mbps	QPSK/16QAM/64QAM
Category 6	300Mbps	QPSK/16QAM/64QAM
LTE-FDD Device Category (Uplink)		
LTE-FDD Device Category (Uplink)	Max Data Rate (Peak)	Modulation Type
Category 1	5Mbps	QPSK/16QAM
Category 2	25Mbps	QPSK/16QAM
Category 3	50Mbps	QPSK/16QAM
Category 4	50Mbps	QPSK/16QAM
Category 5	75Mbps	QPSK/16QAM/64QAM
Category 6	50Mbps	QPSK/16QAM

SIMCom
Confidential

8.2 Related Documents

Table 59: Related documents

No.	Title	Description
[1]	SIM8200 Series_AT Command Manual	AT Command Manual
[2]	ITU-T Draft new recommendation V.25ter	Serial asynchronous automatic dialing and control
[3]	3GPP TS 51.010-1	Digital cellular telecommunications system (Release 5); Mobile Station (MS) conformance specification
[4]	3GPP TS 38.401	NG-RAN; Architecture description
[5]	3GPP TS 34.124	Electromagnetic Compatibility (EMC) for mobile terminals and ancillary equipment.
[6]	3GPP TS 34.121	Electromagnetic Compatibility (EMC) for mobile terminals and ancillary equipment.
[7]	3GPP TS 34.123-1	Technical Specification Group Radio Access Network; Terminal conformance specification; Radio transmission and reception (FDD)
[8]	3GPP TS 34.123-3	User Equipment (UE) conformance specification; Part 3: Abstract Test Suites.
[9]	EN 301 908-02 V2.2.1	Electromagnetic compatibility and Radio spectrum Matters (ERM); Base Stations (BS) and User Equipment (UE) for IMT-2000. Third Generation cellular networks; Part 2: Harmonized EN for IMT-2000, CDMA Direct Spread (UTRA FDD) (UE) covering essential requirements of article 3.2 of the R&TTE Directive
[10]	EN 301 489-24 V1.2.1	Electromagnetic compatibility and Radio Spectrum Matters (ERM); Electromagnetic Compatibility (EMC) standard for radio equipment and services; Part 24: Specific conditions for IMT-2000 CDMA Direct Spread (UTRA) for Mobile and portable (UE) radio and ancillary equipment
[11]	IEC/EN60950-1(2001)	Safety of information technology equipment (2000)
[12]	3GPP TS 51.010-1	Digital cellular telecommunications system (Release 5); Mobile Station (MS) conformance specification
[13]	GCF-CC V3.23.1	Global Certification Forum - Certification Criteria
[14]	2002/95/EC	Directive of the European Parliament and of the Council of 27 January 2003 on the restriction of the use of certain hazardous substances in electrical and electronic equipment (RoHS)
[15]	SIM8200EA-M2 Series_UART_Application Note_V1.xx	This document describes how to use UART interface of SIMCom modules.
[16]	SIM8200EA-M2 Series_GPS_Application Note_V1.xx	GPS Application Note
[17]	3GPP TS 38.101	NR radio transmission and reception technical specification
[18]	SIM8200EA-M2 Antenna design guidelines for diversity receiver system	Antenna design guidelines for diversity receiver system

8.3 Terms and Abbreviations







Table 60: Terms and abbreviations

Abbreviation	Description
ADC	Analog-To-Digital Converter
ARP	Antenna Reference Point
BER	Bit Error Rate
BTS	Base Transceiver Station
CS	Coding Scheme
CSD	Circuit Switched Data
CTS	Clear To Send
DAC	Digital-To-Analog Converter
DRX	Discontinuous Reception
DSP	Digital Signal Processor
DTE	Data Terminal Equipment (typically computer, terminal, printer)
DTR	Data Terminal Ready
DTX	Discontinuous Transmission
DPR	Dynamic Power Reduction
DIV	The Diversity Receive signal
EFR	Enhanced Full Rate
EMC	Electromagnetic Compatibility
ESD	Electrostatic Discharge
ETS	European Telecommunication Standard
EVDO	Evolution Data Only
FCC	Federal Communications Commission (U.S.)
FD	(U)SIM fix dialing phonebook
FDD	Frequency Division Dual
FDMA	Frequency Division Multiple Access
FR	Full Rate
GMSK	Gaussian Minimum Shift Keying
GNSS	Global Navigation Satellite System
GPS	Global Positioning System
HR	Half Rate
HSPA	High Speed Packet Access
HSIC	High-Speed Inter-Chip
I2C	Inter-Integrated Circuit
I2S	Inter-IC Sound
IMEI	International Mobile Equipment Identity
LTE	Long Term Evolution
LB	Low Frequency Band
LAA	Limited Access Authorization

MO	Mobile Originated
MSB	Most Significant Bit
MHB	Middle And High Frequency Band
MT	Mobile Terminated
MIMO	Multiple Input Multiple Output
NMEA	National Marine Electronics Association
PAP	Password Authentication Protocol
PBCCH	Packet Switched Broadcast Control Channel
PCB	Printed Circuit Board
PCIe	Peripheral Component Interface Express
RF	Radio Frequency
RMS	Root Mean Square (value)
RTC	Real Time Clock
SIM	Subscriber Identification Module
SMS	Short Message Service
SPI	Serial Peripheral Interface
SMPS	Switched-Mode Power Supply
TDD	Time Division Dual
TDMA	Time Division Multiple Access
TE	Terminal Equipment(also referred to as DTE)
TX	Transmit Direction
TRX	The Diversity Receive signal
VSWR	Voltage Standing Wave Ratio
SM	(U)SIM Phonebook
SGMII	Serial Gigabit Media Independent Interface
NC	Not connect
HSDPA	High Speed Downlink Packet Access
HSUPA	High Speed Uplink Packet Access
ZIF	Zero Intermediate Frequency
WCDMA	Wideband Code Division Multiple Access
VCTCXO	Voltage Control Temperature-Compensated Crystal Oscillator
(U)SIM	Universal Subscriber Identity Module
UHB	Ultra High Frequency Band
UMTS	Universal Mobile Telecommunications System
UART	Universal Asynchronous Receiver Transmitter

8.4 Safety Caution

Table 61: Safety caution

Marks	Requirements
	<p>When in a hospital or other health care facility, observe the restrictions about the use of mobiles. Switch the cellular terminal or mobile off, medical equipment may be sensitive and not operate normally due to RF energy interference.</p>
	<p>Switch off the cellular terminal or mobile before boarding an aircraft. Make sure it is switched off. The operation of wireless appliances in an aircraft is forbidden to prevent interference with communication systems. Forgetting to think much of these instructions may impact the flight safety, or offend local legal action, or both.</p>
	<p>Do not operate the cellular terminal or mobile in the presence of flammable gases or fumes. Switch off the cellular terminal when you are near petrol stations, fuel depots, chemical plants or where blasting operations are in progress. Operation of any electrical equipment in potentially explosive atmospheres can constitute a safety hazard.</p>
	<p>Your cellular terminal or mobile receives and transmits radio frequency energy while switched on. RF interference can occur if it is used close to TV sets, radios, computers or other electric equipment.</p>
	<p>Road safety comes first! Do not use a hand-held cellular terminal or mobile when driving a vehicle, unless it is securely mounted in a holder for hands free operation. Before making a call with a hand-held terminal or mobile, park the vehicle.</p>
	<p>Mobiles operate over radio frequency signals and cellular networks and cannot be guaranteed to connect in all conditions, especially with a mobile fee or an invalid (U)SIM card. While you are in this condition and need emergent help, please remember to use emergency calls. In order to make or receive calls, the cellular terminal or mobile must be switched on and in a service area with adequate cellular signal strength.</p> <p>Some networks do not allow for emergency call if certain network services or phone features are in use (e.g. lock functions, fixed dialing etc.). You may have to deactivate those features before you can make an emergency call.</p> <p>Also, some networks require that a valid (U)SIM card be properly inserted in the cellular terminal or mobile.</p>